

used to remove polar species from non-aqueous solutions. Examples include vitamins in feeds and food, and antibiotics and other additives from feed. Normal-phase chromatography has been used for a number of years and most applications for normal-phase column chromatography may be easily transferred over to normal-phase SPE.

Cation and anion exchange is used to isolate ionic compounds from either aqueous or non-aqueous solutions. Examples of applications are: isolation of weakly basic proteins; removal of acidic pigments from wines and fruit juices; and the removal of organic acids from water. Many of the applications of classical ion exchange may be used in ion-exchange SPE; however, care must be exercised in the use of strong acids and bases with SPE ion-exchange sorbents that are based on a silica matrix. Furthermore, care must be taken not to exceed the ion-exchange capacity of the sorbent.

Finally, sorbents such as aminopropyl, cyanopropyl, and diol can be used for both reversed-phase and normal-phase separations. Many manufacturers supply their sorbents in variety packs, which may be used for methods development. Also quality assurance reports are commonly available for the various sorbents, which is a good indication of their reproducibility.

### Automation of SPE

Automation of a manual SPE method can provide many benefits, which include safety, improved results, and cost savings. Because automated workstations are mechanical they can operate in environments that are hostile, for example, noisy production locations or a refrigerated room. The use of automation results in improved precision because of reduced operator errors compared with manual methods of SPE. For these reasons automation provides for better utilization of resources.

There are many types of automation equipment for SPE. They include semi-automated instruments, workstations that carry out the entire SPE operation without intervention, and robotic systems that carry out many activities besides SPE and are specially customized for the user. Finally, there are on-line SPE-HPLC systems that allow the user to merely add the sample to the autosampler and analyse the sample directly. The concept of on-line SPE is that a sample is pumped and processed onto the SPE cartridge while the liquid chromatograph or gas chromatograph is processing the preceding sample.

*See also:* II/**Chromatography: Liquid:** Column Technology. **Extraction:** Solid-Phase Extraction. III/**Solid-Phase Extraction with Cartridges. Solid-Phase Extraction with Discs.**

### Further Reading

- Fritz JS (1999) *Analytical Solid-Phase Extraction*. New York: John Wiley.
- Hennion M and Pichon V (1994) Solid-phase extraction of polar organic pollutants from water. *Environmental Science and Technology* 28: 576A-583A.
- Horack J and Majors RE (1993) Perspectives from the leading edge in solid-phase extraction. *LC-GC* 11: 74-90.
- McDonald PD and Bouvier ESP (1995) *Solid Phase Extraction Applications Guide and Bibliography, a Resource for Sample Preparation Methods Development, 6th Edition*. Milford, Massachusetts: Waters.
- Poole SK, Dean TA, Oudesma JW and Poole CF (1990) Sample preparation for chromatographic separations and overview. *Analytical Chimica Acta* 236: 3-42.
- Simpson N and Van Horne KC (1993) *Sorbent Extraction Technology Handbook*. Harbor City, CA: Varian.
- Thurman EM and Mills MS (1998) *Solid-Phase Extraction: Principles and Practice*. New York: John Wiley.
- Varian Sample Preparation Products (1992) *Applications Bibliography*. Harbor City, CA: Varian.
- Zief M and Kiser R (1988) *Sorbent Extraction for Sample Preparation*. Phillipsburg, NJ: J. T. Baker.

## SPACE EXPLORATION: GAS CHROMATOGRAPHY

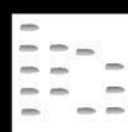

**R. Sternberg and F. Raulin,**  
Universités Paris 12 et 7, CNRS UMR 7583,  
Créteil cedex, France  
**C. Vidal-Madjar,** CNRS UMR 7581,  
Thiais, France

Copyright © 2000 Academic Press

The development in the past 40 years of space exploration has brought important information about the formation and evolution of the solar system and has opened a broad study of organic matter and its continuous chemical evolution which led to the appearance of life.

The study of the physics and chemistry of planetary environments (Table 1) has provided important information about the origin of Earth's early atmosphere and comparative planetology gives a better understanding of our own planet. Titan, the largest satellite of Saturn, because of the composition and density of its atmosphere, is of particular interest for the understanding of the prebiotic chemistry on primitive Earth. Comets are also of interest since they contain very large amounts of organic material and they are considered as the most primitive objects in the solar system, retaining traces of its early evolution.

Since the beginning of space exploration, most of the many probes which have been sent to explore other planetary atmospheres and surfaces have carried analytical instruments to determine the elemental, isotopic and molecular (inorganic and organic) compositions of extraterrestrial environments. Severe constraints are required in space instrumentation such as low weight and small size, low power consumption, high mechanical strength and resistance to deep space conditions. Gas chromatography (GC) fulfils these requirements and is one of the most frequently used technique for *in situ* analysis in space missions.

Chemical sensors based on GC and mass spectrometry (MS) instrumentation have already been used in atmospheric probes or surface landings for analysing extraterrestrial environments, including the analysis of surface materials from Venus and Mars. Until recently, the equipment was only packed column GC with mainly magnetic, then quadrupole mass spectrometers (MS).

Since the Titan atmospheric probe of the Cassini-Huygens mission, launched in 1997 to reach the vicinity of Saturn in 2004, highly sensitive pyrolysis-GC-MS instruments have been developed using capillary columns.

The Rosetta comet exploratory mission, to be launched in 2003, will use, in two GC-based experiments, miniature thermal conductivity detectors (TCDs) and

a new design of time of flight mass spectrometer (TOF), based on a specific geometry of the MS allowing analysis of low mass compounds and good resolution.

This article reviews the different chromatographic instruments used in previous missions to Mars, Venus and Titan as well as those which are being developed, in particular for the forthcoming cometary mission.

## Missions to Mars

Mars is presently the most likely planet on which there is a possibility of finding past, or even present extraterrestrial life. The average atmospheric pressure on its surface is extremely low, about 7 mbar. The primary atmospheric constituent, CO<sub>2</sub>, produces a small warming of the surface above radiation temperature (Table 1).

One of the main objectives of the Viking mission to Mars was the search for Martian life. The US National Aeronautics Space Administration (NASA) sent two identical spacecraft to Mars in 1976. Each Viking lander, carrying scientific instruments, was successfully placed on the surface of Mars. Biemann was responsible for the MS instrument designed mainly for the detection of organic compounds in the GC-MS mode, but also used to determine independently the composition of the minor constituents of the lower atmosphere. In addition, biological investigations were carried out on board the landers. Oyama and Berdahl used GC in a gas exchange experiment (GEX) to determine the gas composition changes above a soil sample humidified or incubated in the presence of an aqueous nutrient.

## Viking GC-MS Experiments

The GC-MS system (Table 2) was designed to analyse the organic compounds released from a heated surface sample. It consists of different sub-systems: (1) three sample ovens mounted in a sample holder, (2) a GC, (3) an effluent divider to protect the MS, (4) a carrier gas separator and (5) the MS itself.

**Table 1** Extraterrestrial environments already analysed or planned to be analysed by gas chromatography

	Distance to sun (AU)	Surface temperature (°C)	Surface pressure (bar)	Atmosphere	
				Major constituents	Organic compounds
Venus	0.7	460	90	CO <sub>2</sub> , N <sub>2</sub>	None
Earth	1	22	1	N <sub>2</sub> , O <sub>2</sub>	Many
Mars	1.5	-70 to 20	0.007	CO <sub>2</sub> , N <sub>2</sub>	Not detected
Titan	9.6	-180	1.5	N <sub>2</sub> , CH <sub>4</sub>	Several hydrocarbons and nitriles
Comets	1.1-5.1	-200	< 0.001	H <sub>2</sub> O, CO, CO <sub>2</sub> , H <sub>2</sub> CO, CH <sub>3</sub> OH	Many

**Table 2** An overview of gas chromatography instruments of *in situ* planetary missions

Mission	Launch arrival	Experiment sample size	Analytical columns	Temperature carrier gas	Detectors
NASA Viking–Mars	1975/1976	GEX 0.1 cm <sup>3</sup> (gas)	One pair of Porapak Q (7.6 m × 1 mm)	24°C, He	1 Thermistor TCD (32°C)
		GC–MS 0.06 cm <sup>3</sup> (soil)	One Tenax coated with polymetaphenoxylene (2 m × 0.76 mm)	50°C (12min) + linear prog. to 200°C, H <sub>2</sub>	MS
NASA Pioneer–Venus–Venus	1978/1978	LGC 0.35 cm <sup>3</sup> (gas)	In parallel: one pair of Porapak N (15.85 m × 1.1 mm); one pair of PDVB (2.13 m × 1.1 mm)	18°C, He 62°C, He	In parallel: two thermistor TCDs
USSR Venera12–Venus	1978/1978	SIGMA GC (gas)	In series: one Polysorb (2 m) 1 molecular sieve (2.5 m); one reduced manganese	70°C, Ne	In series: three Ne ionization
USSR Vega–Venus	1984/1985	SIGMA-3 GC (gas and aerosol)	In parallel: one Porapak QS + N; one Porapak QS + N; one Porapak T	70°C, He, N <sub>2</sub> , N <sub>2</sub>	He ionization + TCD; ECD; ECD
NASA/ESA Cassini–Huygens–Titan	1997/2004	GC–MS (gas and aerosol)	In parallel: one carbon molecular sieve (2 m × 0.75 mm); one glassy carbon WCOT (14 m × 1.8 mm); 1 CPP–DMPS WCOT (10 m × 1.8 mm)	H <sub>2</sub> isothermal 30–60°C	Five MS sources (three connected to each column)
ESA Rosetta–comet P/Wirtanen	2003/2011	COSAC/GC–MS (nucleus)	In parallel: six WCOT capillaries; two PLOT capillaries	He 30–60°C	One MS, eight nano TCDs
		PTOLEMY/GC–MS (nucleus)	Two WCOT capillary; one He chemical trap; one cold trap		One MS

For both instruments on the Viking Lander-1 (VL-1) and Viking Lander-2 (VL-2), one sample oven could not operate and the analyses were limited to four samples from the Martian surface. Two were from the Chryse Planitia region (VL-1) and other two from Utopia Planitia (VL-2). For each sample, a number of analyses were performed with various GC oven temperature (50, 200, 350 or 500°C). The GC–MS operated successfully, as contaminant peaks (methyl chloride, fluorocarbon) were detected. The analysis of Martian soil samples demonstrated the absence of organic compounds above the detection limit of the GC–MS instrument (a few ppb for the more volatile organic compounds).

### Viking Gas Exchange Experiments (GEX)

The biology instrument system had three different experiments integrated in the same package: the pyrolytic release, the label release and the gas exchange

(GEX) experiments. In the GEX experiments Martian soil samples were introduced, and a GC, with thermal conductivity detection (TCD), measured ppm concentrations of metabolic gases such as methane. An incubation gas (a mixture of CO<sub>2</sub>, He and Kr) was introduced into the test cell and the biological activity was stimulated either by humidifying the soil or by adding a nutrient solution in the incubation chamber (temperature between 5 and 27°C). The changes in the composition of the incubation gas were measured periodically with a miniaturized GC.

The GC instrument (Table 2) was designed to analyse light gases such as N<sub>2</sub>, O<sub>2</sub>, CH<sub>4</sub>, Kr, Ne and CO<sub>2</sub> at detection limits ranging from 20 to 60 ppm. Ar and CO were co-eluted on the Porapak Q column used. The composition of the Martian atmosphere was determined by GC at both landing sites (four analyses). The mean abundances were: CO<sub>2</sub> 96.2%, N<sub>2</sub> 2.3%, O<sub>2</sub> < 2.3% and Ar 1.5%, assuming that Ar abundance is an order of magnitude larger than for CO.

The gas changes that occurred in the incubation chamber of the GEX have raised much debate. The decrease of CO<sub>2</sub> just after wetting the sample material has been explained by pH changes. The significant amount of O<sub>2</sub> and its increase by humidifying the sample could be due to the decomposition of inorganic oxidants in the Martian soil.

## Missions to Venus

Extreme temperatures (up to 460°C) and pressures (up to 90 atm) are encountered during the descent, with many reactive materials in a mainly CO<sub>2</sub> atmosphere (Table 1). The clouds of the lower atmosphere are composed of droplets of sulfuric acid. In a number of experiments, the very short time of descent of the probe through the Venusian atmosphere limited the time available for GC analysis.

### Pioneer Venus Gas Chromatograph

The GC on board the sounder probe of the NASA Pioneer Venus mission was designed by Oyama and co-workers for the *in situ* measurement of the composition of the lower atmosphere of Venus. It is a modified version of the GC used in the Viking GEX (Table 2). The separation was performed on the two different analytical columns, each connected to a TCD. The analysis of light gases (mainly Ne and CO) was performed at 16°C, using a long column packed with Porapak N. The short column packed with a polydivinyl benzene (PDVB) porous polymer was used for separating gases from CO<sub>2</sub> to SO<sub>2</sub> at 62°C.

The Pioneer Venus probe entered the Venusian atmosphere on December 1978. During the time for the probe to reach the surface (54 min), the GC analysed three atmospheric samples at 52, 42 and 22 km altitudes. Chlorofluorocarbons were added to the third sample in order to calibrate the instrument. Table 3 gives the Venus atmospheric composition at

different altitudes from the Pioneer Venus GC measurements. The water result is consistent with the value of the vapour pressure in presence of sulfuric acid solutions.

For Ar, the lower abundance, as published in an earlier paper, was due to an incorrect identification (Ar was identified as O<sub>2</sub> and CO as Ar) as the assignment of the peaks was made on the basis of absolute retention times. Later, a correction accounting for flow rate variations and relying on retentions relative to those of Freon internal standards was published.

### Venera 12 Gas Chromatograph

In December 1978 the *in situ* analysis of the chemical composition of the Venusian atmosphere was performed by Gelman and co-workers with a GC on board the USSR Venera 12 lander. The SIGMA instrument (Table 2) consists of three GC units arranged in series, each with a column connected to a pure neon ionization detector operating in the current-saturation mode with  $\beta$ -sources of different activities.

A column packed with a modified sorbent was used to separate H<sub>2</sub>S, COS, SO<sub>2</sub> and H<sub>2</sub>O, in the presence of CO<sub>2</sub>. The low boiling point gases (O<sub>2</sub>, N<sub>2</sub>, Kr, CH<sub>4</sub> and CO) were analysed with a column packed with molecular sieves. The third column (a chemical reactor packed with reduced manganese) was used to obtain the Ar content. The columns and detectors were thermostatted at 70°C.

Since the ionization detectors are sensitive to carrier gas (neon) contamination, the whole GC system was pressurized during storage and flight. Eight samples were analysed from a 42 km altitude to the surface, with 18 chromatograms for the separation of sulfur compounds (first detector) and 27 for light gases (second detector). The GC of the Venera mission could not analyse for Ne, as this was used as the carrier gas. The Ar abundance (Table 3) was determined from its response as a negative peak. This

**Table 3** Gas chromatography measurements of the lower atmospheric composition of Venus

	Mission				
	Pioneer-Venus			Venera 12	Vega
Altitude (km)	52	42	22	0–42	60–55
CO <sub>2</sub> (% by volume)	95.4	95.9	96.4 ± 0.1		
N <sub>2</sub> (% by volume)	4.60 ± 0.14	3.54 ± 0.04	3.41 ± 0.01	2.5 ± 0.5	
H <sub>2</sub> O (% by volume)	<0.06	0.52 ± 0.07	0.135 ± 0.015	<0.01	
Ne (ppm by volume)	<8	11	4.3 ± 0.7		
O <sub>2</sub> (ppm by volume)	44 ± 25	16 ± 7		<20	
Ar (ppm by volume)	60.5	63.8 ± 13.6	67.2 ± 2.3	40 ± 20	
CO (ppm by volume)	32	30 ± 18	19.9 ± 3.1	28 ± 14	
SO <sub>2</sub> (ppm by volume)	<600	176	185 ± 43	130 ± 60	<100
H <sub>2</sub> SO <sub>4</sub> (mg m <sup>-3</sup> ) aerosol					~1

behaviour enabled estimation of the O<sub>2</sub> mixing ratio (<2.10–3.00% by volume) as the GC of Venera instrument did not directly measure O<sub>2</sub> concentration (O<sub>2</sub> coelutes with Ar). The values of Ar and O<sub>2</sub> mixing ratios lie in the same range of experimental error as the revised data of the Pioneer Venus GC.

Measuring atmospheric composition with different instruments is clearly advantageous, allowing cross-checks and preventing measurement errors. The quite good agreement of the data in Table 3 validates the results and gives a reasonable basis for models of Venusian atmospheric chemistry.

### Vega GC Experiments

The two spacecraft of the Vega mission reached Venus in June 1985. The atmospheric probes (Vega 1 and 2) used a balloon to allow an hour's duration for the descent into the Venusian atmosphere. The SIGMA-3 GC on board each probe was designed by Mukhin and co-workers for the analysis of the gases and aerosols of the Venus cloud layer (60–55 km altitude). Three GC sub-units were arranged in parallel, each having a column connected to a different detector. Three different detectors were used: a helium ionization detector, a TCD and an electron-capture detector (ECD). The carrier gas was helium except for the sub-unit employing the ECD (carrier gas: ultrapure N<sub>2</sub>). The separation of H<sub>2</sub>S, COS and SO<sub>2</sub> in the presence of CO<sub>2</sub> and water vapour was performed at 70°C, with a column packed with a mixture of Porapak QS and Porapak N.

In the gas analysis mode, the sample was heated at 80°C and directly injected on to the column. At the sampling altitude (60–55 km) the experiment demonstrated the absence of H<sub>2</sub>S, COS and SO<sub>2</sub> down to the detection limit of the GC instrument (10–100 ppm, depending on the substance). In the pyrolytic mode, the cell containing a carbonized fibre-glass filter was heated at 350°C. At this temperature H<sub>2</sub>SO<sub>4</sub> is broken down into CO<sub>2</sub>, H<sub>2</sub>O and SO<sub>2</sub>. The comparison of flight experiments with simulation data enabled estimation of the concentration of H<sub>2</sub>SO<sub>4</sub> in the Venusian atmosphere to be about 1 mg m<sup>-3</sup> for the 60–55 km altitude range.

### Missions to Titan

Titan, a giant satellite of Saturn, has a dense atmosphere (Table 1). As with the Earth's atmosphere the main constituent is N<sub>2</sub>. CH<sub>4</sub> is present at a low percentage. Traces of other organic compounds were revealed by Voyager's infrared spectrometer. The presence of these compounds was also predicted by Raulin and co-workers from the results of laboratory simulations. In addition, the atmosphere contains

aerosols and cloud droplets that obscure the surface of the satellite.

One of most important goals of the Cassini-Huygens mission to Titan is the *in situ* analysis of the composition of Titan's atmosphere. Successfully launched on October 1997, the NASA spacecraft (Cassini) carries a probe (Huygens) provided by the European Space Agency (ESA). After release from the orbiter in November 2004, the probe will slowly descend to Titan by deploying three parachutes. The six scientific experiments on the probe are designed to determine the physical and chemical properties of the atmosphere and the surface of Titan. Among these instruments are the GC-MS and the aerosol collector and pyrolyser (ACP).

### Huygens GC-MS Experiments

The main objective of the GC-MS designed by Niemann and co-workers is to measure the chemical composition of the stratosphere and troposphere (from 170 km to the surface) during the 2.5 h descent. The GC-MS connected to the ACP will determine the nature and the abundance of the organic and inorganic compounds present in the atmosphere, both in the gaseous phase and in the aerosols themselves.

Three columns operating in parallel will be used to separate the expected species of Titan's atmosphere (Table 2). The identification and detection are achieved by connecting each column to an independent MS ion source. The MS (quadrupole, range 2–150 amu) will operate in two modes, either coupled to the GC or independently, by direct sample injection (Figure 1). For many substances (noble gases and many organics) mixing ratios as low as 0.1 ppb will be detected.

Capillary columns will be used for the first time for the *in situ* analysis of an extraterrestrial planetary atmosphere. Sternberg and co-workers selected the columns of the Cassini-Huygens mission for their compatibility with the severe constraints imposed by the experiment: fast analysis time, stability of the stationary phase (vacuum, cosmic rays, high energy electronic bombardment, inlet carrier gas pressure, 1.4–1.9 bar, outlet flow-rate of <1 mL min<sup>-1</sup>, isothermal analysis in the range of 30–60°C. The first column, a carbon molecular sieve micro-packed column, will be used to separate light gases such as N<sub>2</sub> to CH<sub>4</sub>. The second, a wall-coated open-tubular (WCOT) capillary column of glassy carbon will be used to separate low molecular mass hydrocarbons (C<sub>1</sub>–C<sub>3</sub>). The analysis of the saturated and unsaturated hydrocarbons (C<sub>4</sub>–C<sub>8</sub>) and the nitriles (up to C<sub>4</sub>) will be achieved using a silicosteel WCOT capillary column having a slightly polar

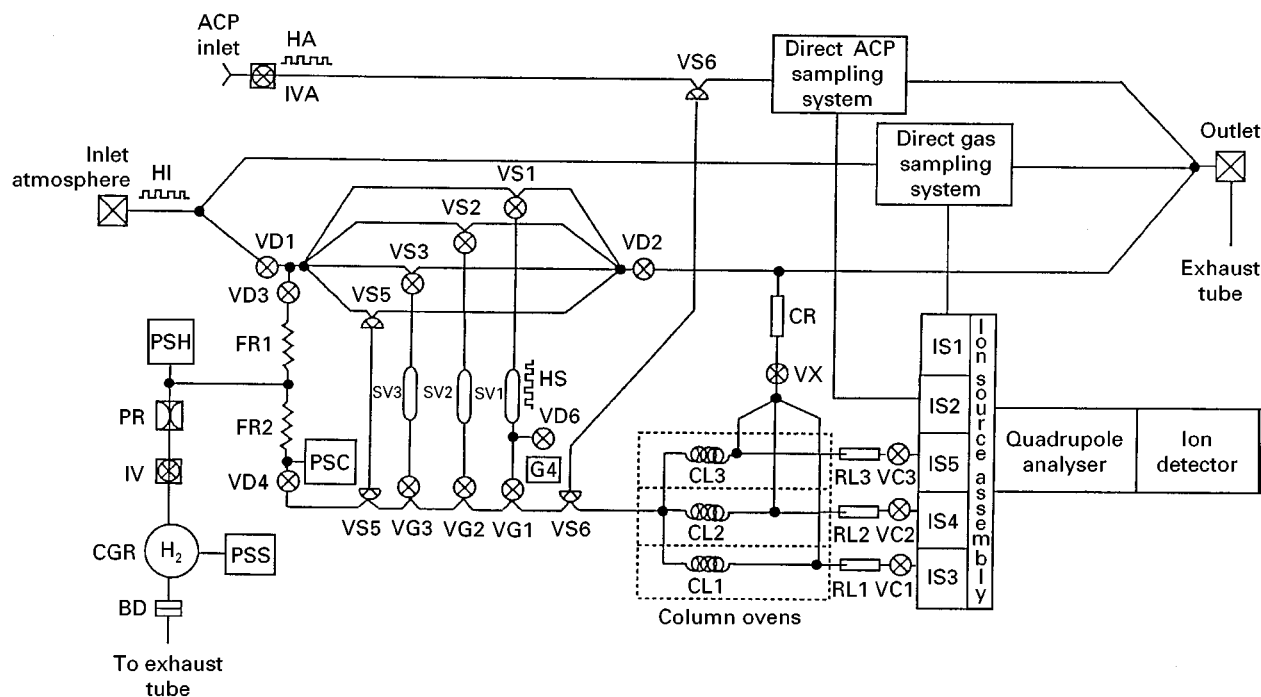

**Figure 1** Schematic diagram of the GC-MS instrument on board Huygens. Abbreviations: ACP, aerosol collector pyrolyser; BD, burst diaphragm; CL, column; CR, column restrictor; CGR, carrier gas reservoir; FR, flow restrictor; G, getter pump; HA, heater (inlet ACP); HI, heater (inlet atmosphere); HS, heater (sample volume); IV, isolation valve (H<sub>2</sub> system); IVA, isolation valve (inlet ACP); PR, pressure reducer; PSH, pressure sensor (H<sub>2</sub> tank); PSC, pressure sensor (column); RL, restrictor leak; SV, sample volume; VC, valve (column); VD descent/analysis control valve; VG, sample/carrier gas valve; VS, sample valve. (Reproduced from Sternberg R, Szopa C, Coscia D, Zubrzycki S, Raulin F, Vidal-Madjar C, Niemann H and Israel G (1999) Gas chromatography in space exploration. Capillary and micropacked columns for in-situ analysis of Titan's atmosphere. *Journal of Chromatography A* 846: 307 with permission of Elsevier Science.)

stationary phase: cyanopropyl phenyl (CPP) dimethylpolysiloxane (DMPS) (Figure 2).

### Aerosol Collector and Pyrolyser (ACP) Instrument

The ACP instrument was designed by Israel and co-workers to sample and collect the aerosols of Titan's atmosphere, and then to transfer the products from evaporation or pyrolysis to the Huygens GC-MS, for analysis. The aerosols are collected on a multilayered stainless filter by direct impaction for the first sampling (135–80 km). A pump is used at lower altitudes (80–32.5 km) and (22–17 km) to draw the atmosphere through the filters for the two other samplings. The filter is moved to an oven and heated at 250° or 600°C. Labelled nitrogen is used to transfer the gas and pyrolytic products to the GC-MS.

Each sample will be analysed using the direct MS mode. The GC-MS analysis will be performed once with the 600°C pyrolysis sequence. The tests for validating the ACP-GC-MS experiment were made by analysing the products synthesized by Raulin, Coll and co-workers when the photolytic and radiolytic processes expected in Titan's atmosphere were simulated (Figure 3).

### Mission to Comets

It is generally believed that cometary nuclei, due to their formation in the outer solar system at very low temperatures, should retain the composition of the solar nebula and thus the average composition of the solar system. Considered as the most primitive bodies of the solar system, comets are believed to have seeded Earth with organic matter and water (Table 1) through numerous impacts on the surface of the primitive Earth. Therefore, cometary exploration is of primary importance for a better understanding of the solar system, as well as the origin of life on Earth. Following several cometary fly-by missions (e.g. GIOTTO, VEGA) which provided the first images of a cometary nucleus and *in situ* measurements of the composition of gas and dust released from the surface, the ESA Rosetta mission will explore the nucleus of P/Wirtanen comet. The ESA Rosetta mission will be launched in 2003 and after two gravity-assisted fly-bys of Earth and Mars, it will reach the comet in 2011. The Rosetta mission will include a spacecraft and a landing probe for the *in situ* analysis of the cometary nucleus and its environment. The scientific

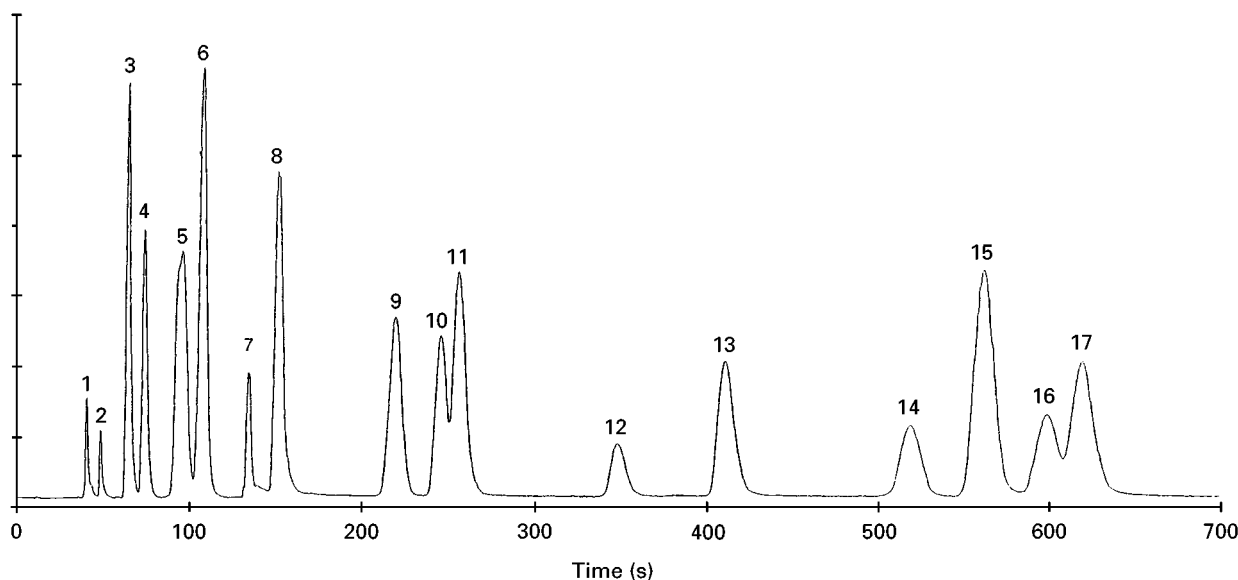

**Figure 2** Chromatogram of a mixture of hydrocarbons and nitriles with the CPP-DMPS (14 : 86) WCOT capillary column for *in situ* analysis of Titan's atmosphere. Capillary column MXT 1701 (10 m  $\times$  0.18 mm). Carrier gas, He; temperature, 30°C, pressure drop, 0.3 bar. (1) Methane, (2) 1-butene, (3) n-pentane + 1-pentene, (4) 2-methyl-2-butene, (5) cyclopentane + 3-methylpentane, (6) n-hexane + 1-hexene, (7) acetonitrile, (8) acrylonitrile, (9) n-heptane + cyclohexene, (10) benzene + methacrylonitrile, (11) propionitrile, (12) iso-butyronitrile, (13) *cis*- or *trans*-crotonitrile, (14) n-octane, (15) butyronitrile, (16) toluene, (17) *cis*- or *trans*-crotonitrile. (Reproduced from Sternberg R, Szopa C, Coscia D, Zubrzycki S, Raulin F, Vidal-Madjar C, Niemann H and Israel G (1999) Gas chromatography in space exploration. Capillary and micropacked columns for *in situ* analysis of Titan's atmosphere. *Journal of Chromatography A* 846: 307 with permission from Elsevier Science.)

payload of the cometary lander includes two instruments for chemically analysing the surface.

The first experiment, named COSAC (cometary sampling and composition experiment), has been built by Rosenbauer and co-workers at the Max-Planck-Institut für Aeronomie (Lindau, Germany) and the second, Modulus (method of determining and

understanding light elements from unequivocal stable isotope compositions), has been built by Pillinger and co-workers at the Planetary Science Research Institute, Open University (Milton Keynes, UK). These two instruments will use state-of-the-art GC techniques, involving pyrolysis and MS.

### Cometary Sampling and Composition (COSAC) Experiments

The COSAC experiments by Py-GC-MS are designed to analyse gases either sampled directly from the atmosphere around the nucleus, or provided by the heating of nucleus material collected by the lander's sampler which can drill to a depth of at least 20 cm.

The pyrolyser consists of micro-ovens, mounted on a carousel, which allow vaporization by stepwise heating of the cometary solid sample. The GC subsystem contains eight capillary columns divided into two packages of four sharing a common injector. Up to four columns, which can be selected individually, can be operated in parallel in the temperature range 0–200°C. GC detection is performed by miniature solid-state thermal conductivity detectors. COSAC can be used as a stand-alone instrument or can be coupled to the time-of-flight (TOF) MS. Five of the GC columns are WCOT and PLOT columns dedicated to general chemical composition analysis. In term of speed, efficiency, weight and carrier

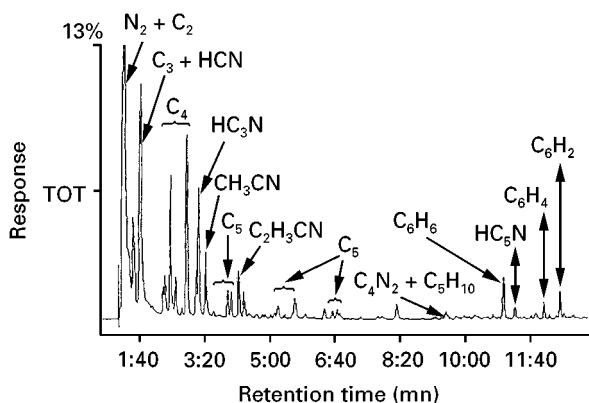

**Figure 3** GC-MS analysis of a gaseous sample obtained after irradiation (5 h spark discharge) of a gas mixture of  $N_2$  (800 mbar) and  $CH_4$  (13 mbar) at 100–150 K. Capillary column CP-Sil-5CB (25 m  $\times$  0.15 mm). Carrier gas, He; temperature, 20°C, then programmed at low temperature (< 150°C). (Adapted from Coll P, Guillemin JC, Gazeau MC and Raulin F (1999) Report and implications of the first observation of  $C_4N_2$  in laboratory simulations of Titan's atmosphere. *Planetary Space Science* 47: 1433–1440.)

gas flow-rate, these PLOT capillary columns will advantageously replace packed columns. The three other columns will be dedicated to the measure of chirality. Using chiral stationary phases they will be able to separate enantiomers, and thus determine the eventual presence of an enantiomeric excess.

Due to the large fraction (50%) of water vapour which is expected in the cometary sample, a single chemical water trap will be placed ahead of the columns. The mass of the COSAC experiment is constrained to 4.38 kg and the average power consumption during operation should not exceed 15 W.

### The Modulus GC-MS Experiments

The Modulus experiments will determine the abundance and isotopic composition of major, minor and trace constituents of the cometary nucleus. It uses several analytical trains in parallel, each set composed of: chemical reactors to quantitatively chemically transform the cometary samples into very light volatile compounds, GC columns to purify and separate the resulting gases and detectors, including an ion trap MS, to quantitatively analyse these gases.

By converting the elements of interest into specific gases of low molecular weight such as O<sub>2</sub>, CO<sub>2</sub>, N<sub>2</sub> and CH<sub>4</sub>, the Modulus experiment only requires a MS of low mass range with limited resolution. Thus, it uses an ion trap MS with a mass of 10–20 g (not including its power supply). The entire experiment could require less than 3 kg weight and 5 W of power. Two WCOT capillary columns, one of which has a ceramic coating stationary phase, will be used. Highly specific to volatiles (including permanent gases and water) this stationary phase is robust and withstands space constraints. It has to be noted that a variant of this experiment will equip the Orbiter craft to enable a comparative study between the chemical composition of the coma and the nucleus to be carried out.

### Future Developments

Mars is the most interesting planet to study because it may once have had an atmosphere similar to that of the primitive Earth. In the next decade, an extensive space programme will be devoted to the exploration of the planet with the purpose of comparing its evolution with that of the Earth. The most consistent explanation for the Viking failure to detect organic molecules lies in photochemically produced oxidants (such as H<sub>2</sub>O<sub>2</sub>) which originated in the atmosphere and diffused into the soil, and are potential sources of degradation of organic compounds. Missions, such as the Mars Sample Return (to be launched in 2007) are now being planned with a landing probe

including an experiment for exobiological characterization of the Martian surface material. The objectives of these missions, in the frame of a large international programme involving NASA, ESA, CNES and other national space agencies, are to search for subsurface water as well as for traces of life (past and present), organic compounds and oxidants. Several instruments on board the lander, among them a Py-GC-MS, will perform an *in situ* analysis of the subsurface, at depths where the effects of ultraviolet radiation and oxidizing agents are negligible.

Space instrumentation, because of its many constraints, has brought about several technological developments in the field of chromatography and has opened the way for the chemical analysis of more complex compounds in extraterrestrial environments. But there is a need of new instrumentation for the analysis of non-volatile and/or thermally fragile organic compounds, such as amino acids, incompatible with pyrolysis techniques. The adaptation of high-performance liquid chromatography (HPLC) and supercritical fluid chromatography (SFC) to space conditions seems difficult. Chemical derivatization coupled to GC (CD-GC) might be the solution. The development of an automated chemical derivatization process is under investigation and could be used for the *in situ* analysis of the Martian soil in forthcoming missions to Mars.

*See also: II/Chromatography: Gas: Detectors: General (Flame Ionization Detectors and Thermal Conductivity Detectors); Detectors: Mass Spectrometry; Detectors: Selective; Pyrolysis Gas Chromatography; Sampling Systems. III/Atmospheric Analysis: Gas Chromatography. Chiral Separations: Gas Chromatography. Gas Analysis: Gas Chromatography.*

### Further Reading

- Biemann K, Oro J, Toulmin III P, Orgel LE, Nier AO, Anderson DM, Simmonds PG, Flory D, Diaz AV, Rushneck DR, Biller JE and Lafleur AL (1977) The search for organic substances and inorganic volatile compounds in the surface of Mars. *Journal of Geophysical Research* 82: 4641.
- Coll P, Guillemin JC, Gazeau MC and Raulin F (1999) Report and implications of the first observation of C<sub>4</sub>N<sub>2</sub> in laboratory simulations of Titan's atmosphere. *Planetary Space Science* 47: 1433–1440.
- Gelmen BG, Zolotukhin VG, Lamonov NI, Levchuk BV, Mukhin LM, Nenarokov DF, Okhotnikov BP, Rotin VA and Lipatov AI (1979) Venera 12 analysis of Venus atmospheric composition by gas chromatography. *Pris'ma v Astronomicheskii Zhurnal* 5: 217.
- Israel G, Cabane M, Coll P, Coscia D, Raulin and Niemann H (1999) The Cassini-Huygens ACP experiment and exobiological implications. *Advances in Space Research* 23: 319.



- Mahaffy PR, A'Hearn MF, Atreya SK, Bar-Nun A, Bruston P, Cabane M, Carignan GR, Coll P, Crifo JF, Ehrenfreund P, Harpold D, Gorevan S, Israel G, Kasprzak W, Mumma MJ, Niemann HB, Owen T, Raulin F, Riedler W, Schutte W, Sternberg R and Strazzulla G (1999) The Champollion cometary molecular analysis experiment. *Advances in Space Research* 23: 349.
- Mukhin LM, Nenarokov DF, Porschnev NV, Bondarev VB, Gelman BG, Israel G, Raulin G, Runavot J and Thomas R (1987) Preliminary calibration results of Vega 1 and 2 SIGMA-3 gas chromatograph. *Advances in Space Research* 7: 329–335.
- Niemann H, Atreya S, Bauer SJ, Biemann K, Block B, Carignan G, Donahue T, Frost S, Gautier D, Harpold D, Hunten D, Israel G, Lunine J, Mauersberger K, Owen T, Raulin F, Richards J and Way S (1997) The gas chromatograph mass spectrometer aboard Huygens. *European Space Agency (ESA)-SP-1177*: 85–107.
- Oyama VI and Berdahl BJ (1977) The Viking gas exchange experiment results from Chryse and Utopia surface samples. *Journal of Geophysical Research* 82: 4669.
- Oyama VI, Carle GC, Woeller F, Pollack JB, Reynolds RT and Craig RA (1980) Pioneer Venus gas chromatography of the lower atmosphere of Venus. *Journal of Geophysical Research* 85: 7891.
- Rosenbauer H, Fuselier SA, Ghielmetti A, Greenberg JM, Gosemann F, Ulamec S, Israel G, Livi S, MacDermott JA, Matsuo T, Pillinger CT, Raulin F, Roll R and Thiemann W (1999) The COSAC experiment on the lander of the ROSETTA mission. *Advances in Space Research* 23: 333–340.
- Sternberg R, Szopa C, Coscia D, Zubrzycki S, Raulin F, Vidal-Madjar C, Niemann H and Israel G (1999) Gas chromatography in space exploration. Capillary and micropacked columns for in-situ analysis of Titan's atmosphere. *Journal of Chromatography A* 846: 307–315.
- Wright IP and Pillinger CT (1998) Modulus – an experiment to measure precise stable isotope ratios on cometary materials. *Advances in Space Research* 21: 1537–1545.

## STEROIDS

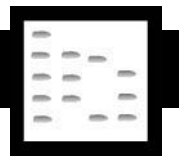

### Gas Chromatography

H. L. J. Makin, St Bartholomew's and the Royal London School of Medicine and Dentistry, London, UK

Copyright © 2000 Academic Press

### Introduction

This review aims to summarize the application of gas chromatography (GC) to the analysis of steroids. The review concentrates mainly on hyphenated GC–mass spectrometry technology as the use of GC linked to detectors other than mass spectrometry (MS) is now decreasing. A survey of literature using MEDLINE indicated that in the period 1990 to date, more than 90% of around 400 references used GC–MS, as might be expected as the mass spectrometer is now the most effective detector for GC and simple, cheap and sensitive bench-top GC–MS systems are now widely available. Use of MS can often compensate for poor GC resolution or peak shape, but use of GC–MS still requires that attention is paid to optimization of both GC and MS behaviour, if maximum sensitivity is required. The MS, of course, has the added advantage that it can provide structural data and can be used to confirm that a GC peak is indeed a steroid. By com-

paring the mass spectrum obtained with those in a library can often identify the steroid. Retention time data, on their own, are not a satisfactory criterion for identification but can be considerable value when combined with MS data.

Steroids range from the  $C_{18}$  oestrogens to  $C_{27}$  sterols such as cholecalciferol (vitamin D) and include androgens, progestagens, corticosteroids and bile acids as well as a large number of synthetic steroids, some of which may be used therapeutically. The formulae of some of these steroid types are illustrated in Figure 1 in III/STEROIDS/Liquid Chromatography and Thin-Layer (Planar) Chromatography. Alternatively readers can consult the *Dictionary of Steroids*, which lists some 10 000 steroids together with their formulae, trivial and systematic names and other useful information.

### Derivatization

Most steroids have melting points in excess of  $150^{\circ}\text{C}$  (estradiol- $17\beta$ , the female sex hormone, for example, has a melting point of  $176^{\circ}\text{C}$ ). It is therefore often necessary to derivatize steroids of interest in order to optimize their GC performance. Derivatization improves volatility, a necessary characteristic as the analyte in GC must be in the vapour phase. High injection (around  $350\text{--}400^{\circ}\text{C}$ ) and column temperatures (up to  $350^{\circ}\text{C}$ ) may also be necessary to achieve