



Potting Bench

This simple pine potting bench is a great help to any gardener. The bottom shelf can store large gardening items that take up space in the garage, and the top shelves can accommodate small pots, insecticides, and other necessities. There is also a drawer for stowing gardening tools. The work surface features a drop-in container to hold potting soil. With this handy potting bench on your side, we bet your garden will be the prettiest in the neighborhood.



Special Tools and Techniques

- Bar clamps
- Mitering

Materials and Supplies

- 32 linear feet of 1 x 8 pine
- 12 linear feet of 1 x 6 pine
- 45 linear feet of 1 x 4 pine
- 10 linear feet of 1 x 2 pine
- 4 linear feet of 1 x 1 pine
- 25 linear feet of 2 x 4 pine
- 1 piece of 3/8"-thick exterior plywood, measuring 2' x 2'
- Heavy-duty plastic dishpan, approximately 11' x 13"

Hardware

- 20 2-1/2" screws
- 50 1-5/8" screws
- 50 1-1/2" screws
- 35 1-1/4" screws
- 10 4d x 1-1/2" nails
- 20 3d x 1-1/4" nails
- 35 2d x 1" nails

Cutting List

Code	Description	Qty.	Materials	Dimensions
A	Horizontal Sides	4	2 x 4 pine	20-1/2" long
B	Vertical Sides	4	2 x 4 pine	33" long
C	Side Trim	2	1 x 4 pine	23-1/2" long
D	Long Trim	1	1 x 4 pine	52-1/2" long
E	Shelf Slat	4	1 x 4 pine	51" long
F	Wide Top	2	1 x 8 pine	60-1/2" long
G	Narrow Top	2	1 x 6 pine	60-1/2" long
H	Edge Support	2	1 x 2 pine	20" long
I	Reinforcements	2	1 x 2 pine	14" long
J	Shelf Sides	2	1 x 8 pine	34" long
K	Shelf Back	2	1 x 4 pine	59" long
L	Shelf	2	1 x 8 pine	59" long
M	Bottom Support	1	2 x 4 pine	59" long
N	Drawer Side	2	3/8" plywood	5" x 6-7/8"
O	Drawer Glides	2	1 x 1 pine	7-1/4" long
P	Drawer Bottom	1	3/8" plywood	14-1/2" x 6-7/8"
Q	Drawer Back	1	3/8" plywood	15-1/2" x 5"
R	Drawer Front	1	1 x 8 pine	18-3/4" long
S	Horizontal Drawer Support	1	1 x 2 pine	22" long
T	Vertical Drawer Support	1	1 x 1 pine	22" long
U	Top Support	2	2 x 4 pine	8" long

Constructing the Side Supports

1. Cut four horizontal sides (A) from 2 x 4 pine, each measuring 20-1/2" long.
2. Cut four vertical sides (B) from 2 x 4 pine, each measuring 33" long.
3. To form the side supports, place two vertical sides (B) parallel to each other and 20-1/2" apart. Fit two horizontal sides (A) between the two vertical sides (B), as shown in *Figure 1*. The uppermost horizontal side (A) should be even with the top ends of both vertical sides (B), and the lower horizontal side (A) should be 6-1/2" from the lower ends of both vertical sides (B). Screw through the vertical sides (B) into the ends of the horizontal sides (A). Use

two 2-1/2"-long screws on each of the joints. Repeat this procedure to form a second side support, using the remaining two vertical sides (B) and horizontal sides (A).

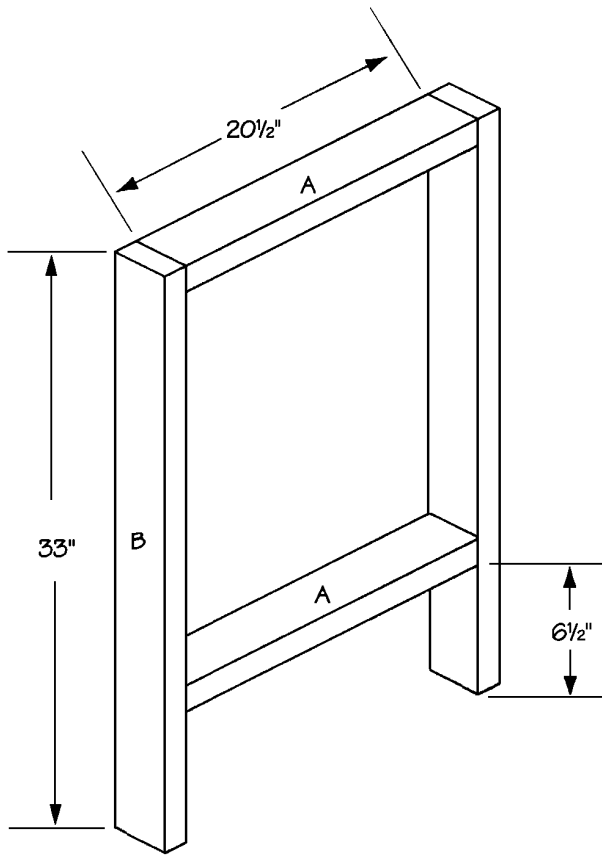

Figure 1

Adding the Trim

1. Cut two side trims (C) from 1 x 4 pine, each measuring 23-1/2" long.

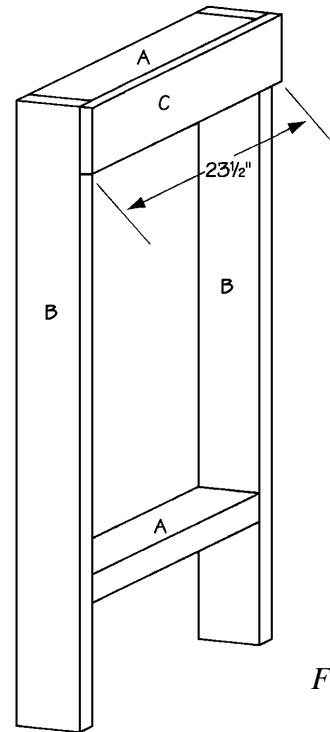

Figure 2

2. Apply glue to the meeting surfaces, and attach one side trim piece (C) to the top of one assembled side support, as own in *Figure 2*. Screw through the side trim (C) into the upper horizontal side (A) and the two vertical sides (B). Use two 1-5/8"-long screws on each of the vertical sides (B) and three screws on the horizontal sides (A). Repeat this procedure to attach the remaining side trim(C) to the other assembled side support.
3. Cut one long trim (D) from 1 x 4 pine, measuring 52-1/2" long
4. Place the two side supports on a level surface, parallel to each other and 44" apart, with the side trim (C) on the outside. Fit the long trim (D) over the exposed ends of the side trim (C), as shown in *Figure 3*. Screw through the long trim (D) into the vertical sides (B). Use two 1-5/8"-long screws on each joint.

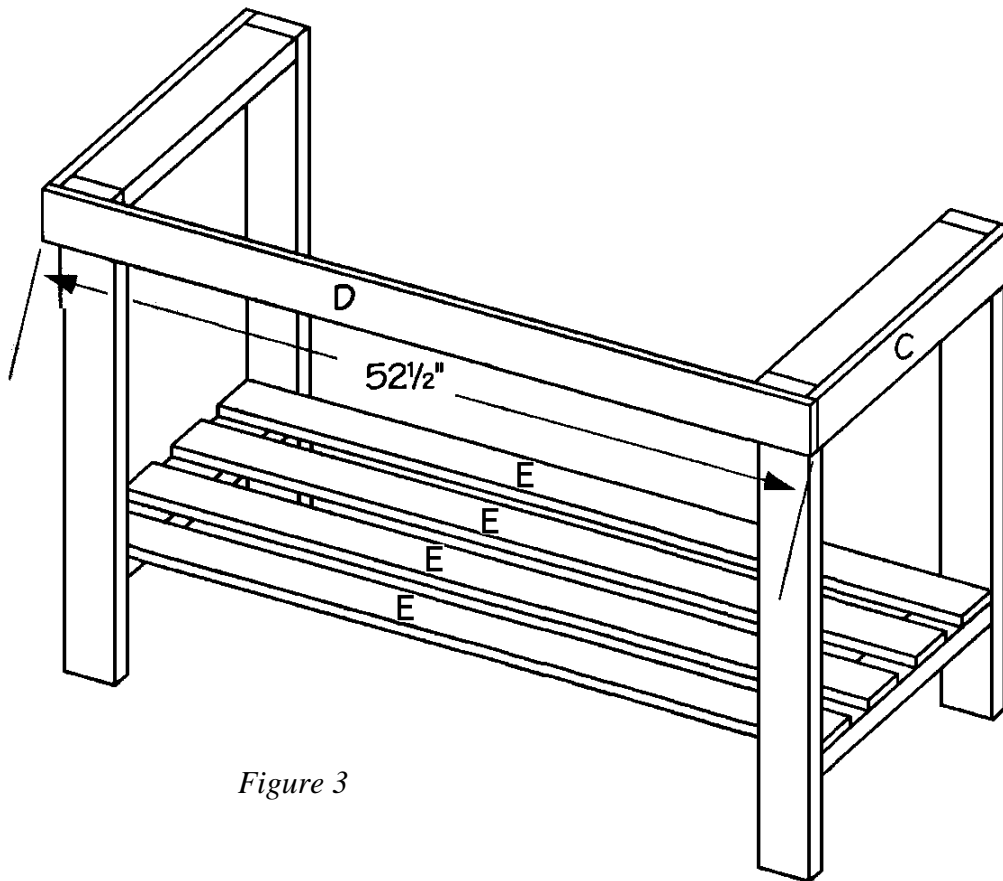

Figure 3

5. Cut four shelf slats (E) from 1 x 4 pine, each measuring 51" long.
6. Position the shelf slats (E) evenly spaced over each of the lower horizontal sides (A), as shown in *Figure 3*. Screw through the ends of the shelf slats (E) into the top of the lower horizontal sides (A), using two 1-5/8" long screws on each joint.

Making the Work Surface

1. Cut two wide tops (F) from 1 x 8 pine, each measuring 60-1/2" long.
2. Cut two narrow tops (G) from 1 x 6 pine, each measuring 60-1/2" long.
3. Place the four tops (F and G) parallel to each other, with the wide tops (F) on the outside and the narrow tops (G) on the inside to form a rectangle measuring 25-1/2" x 60-1/2" as shown in *Figure 4*. Apply glue to the meeting surfaces and clamp the tops together, making certain that all four tops are level along their entire length. Allow the boards to set up overnight.

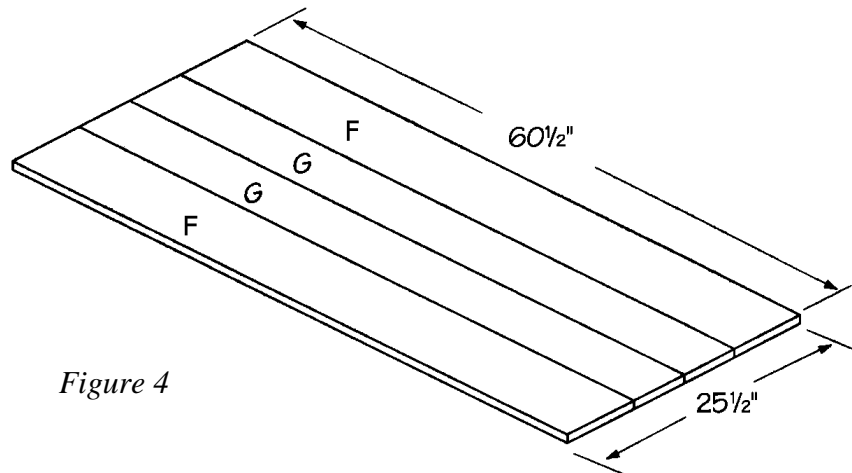

Figure 4

4. Cut two edge supports (H) from 1 x 2 pine, each measuring 20" long. These will be used to reinforce the glued top. Screw them to the rectangular top, positioning them 2-3/4" from the front and back, and 2" from the sides, as shown in Figure 5. Use eight 1-1/4"-long screws on each edge support (H).

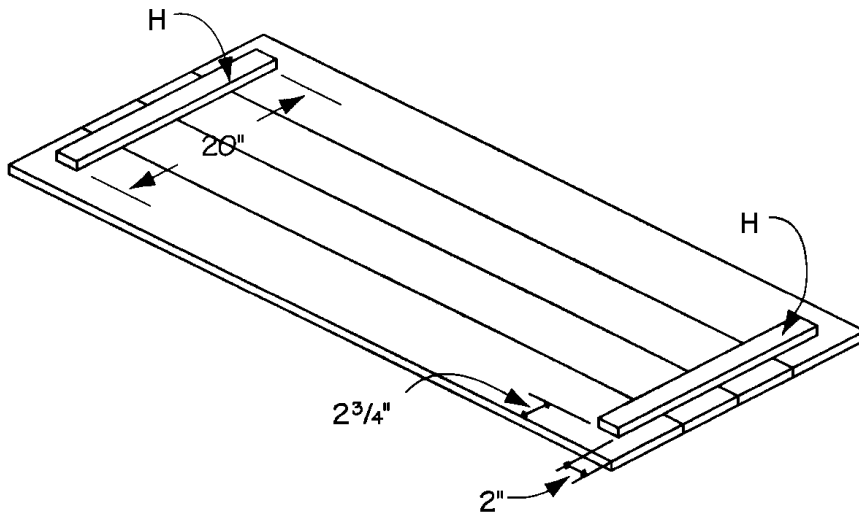

Figure 5

Adding the Potting Bin

1. The next step is to cut a hole in the rectangular top to accommodate the potting bin. We used a heavy-duty plastic dishpan for our bin. With the rectangular top upside down, and the edge supports (H) showing, turn the dishpan upside down in the position shown in Figure 6. Holding the dishpan in that position, trace around it with a pencil to transfer the outline to the wood surface. Remove the dishpan. Draw an inner outline about 1/2" smaller, which will be the true cutting line. This will allow the dishpan to drop through the hole, with the dishpan lip resting on the wood. Make certain that all four sides of your hole are parallel to the four sides of the rectangular top. When you are satisfied that the position and the size of the hole are correct, cut out the center section to accommodate the dishpan.

- To reinforce the top around the edge of the hole, cut two reinforcements (I) from 1 x 2 pine, each measuring 14" long.

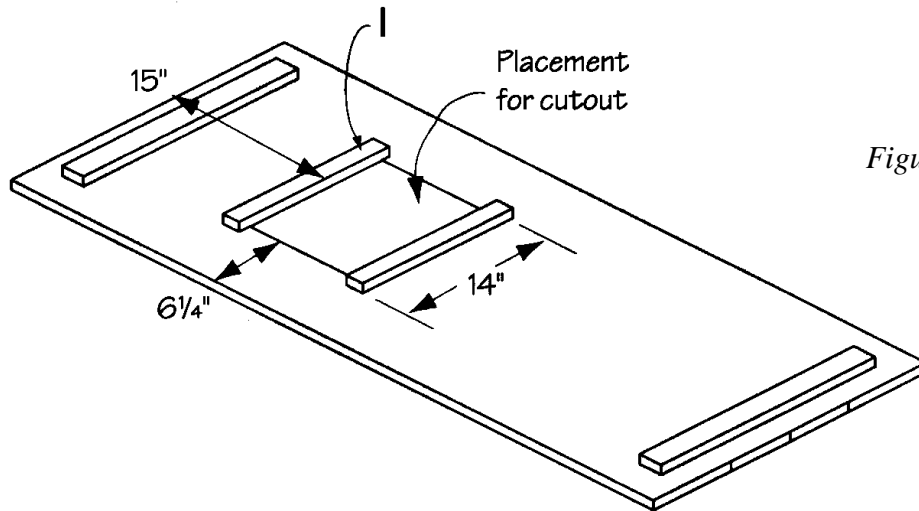

Figure 6

- Place the two reinforcements (I) flush with the long edges of the hole, with an equal length of the reinforcement (I) extending past the hole, as shown in *Figure 6*. Screw through the reinforcements (I) into the rectangular top, using six 1-1/4"-long screws on each reinforcement (I).
- Turn the rectangular top right side up. Center it on top of the side supports. The top should overhang the side supports 4" at the sides and 1-1/2" at the back.
- Attach the rectangular top to the side supports. Screw through the top into each of the side supports using five 1-5/8"-long screws spaced evenly along the joint.

Making the Upper Shelf Section

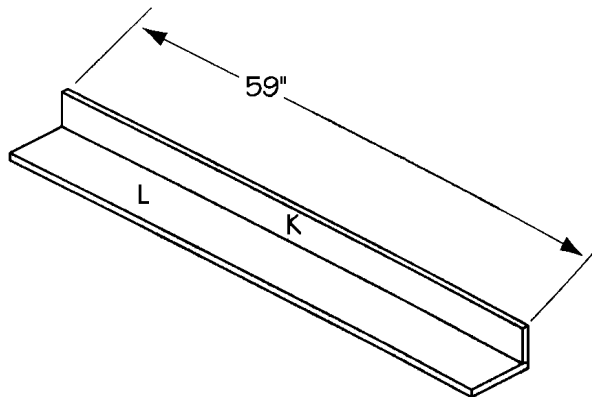
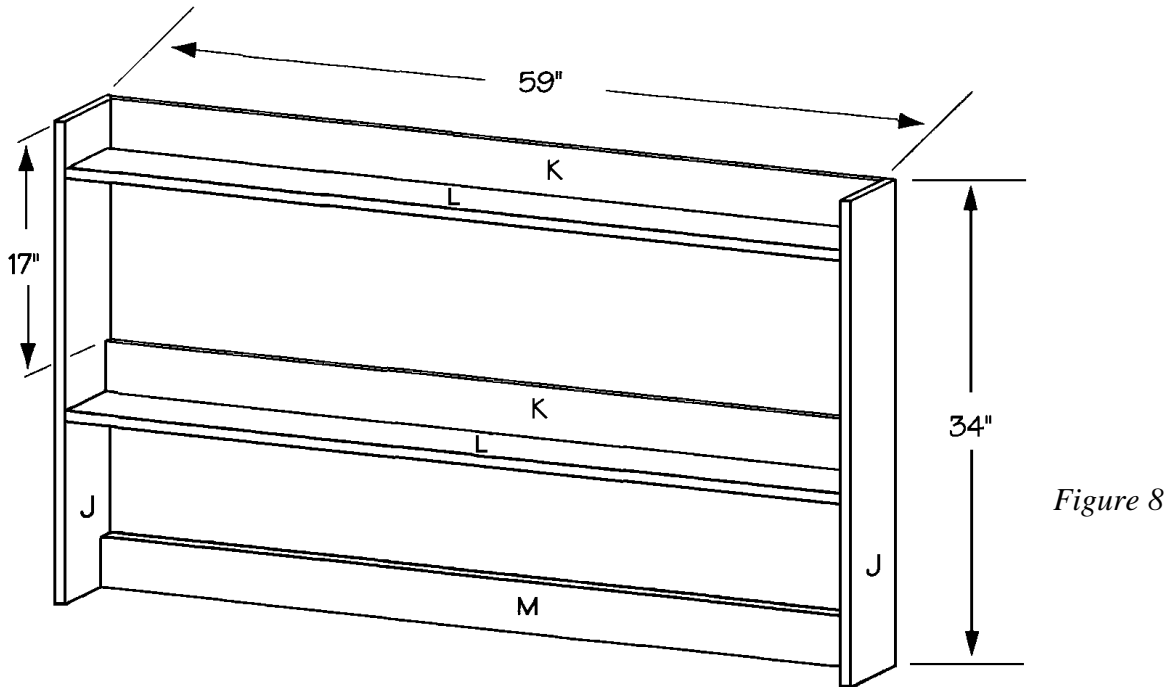

Figure 7

- Cut two shelf sides (J) from 1 x 8 pine, each measuring 34" long.
- Cut two shelf backs (K) from 1 x 4 pine, each measuring 59" long.
- Cut two shelves (L) from 1 x 8 pine, each measuring 59" long.
- Glue one shelf (L) to the edge of one shelf back (K), aligning the bottom s of the two

pieces, as shown in *Figure 7*. Reinforce the joint by driving 1-5/8"-long screws every 6 inches. Repeat this step to join the other shelf (L) and the shelf back (K).

5. Place the two shelf sides (J) on a level surface, parallel to each other, and 59" apart. Fit one shelf/back assembly between the two shelf sides (J), flush with the ends of both shelf sides (J), as shown in *Figure 8*. Screw through the shelf sides (J) in the ends of the shelf back (K) and the shelf (L). Use two 1-5/8"-long screws in each end of the shelf back (K) and three screws in each end of the shelf (L).



6. Repeat Step 5 to attach the remaining shelf/back assembly between the two shelf sides (J), 17" from the top of the shelf sides (J), as shown in *Figure 8*.
7. Cut one bottom support (M) from 2 x 4 pine, measuring 59" long.
8. Attach the bottom support (M) between the two shelf sides (J), flush with the lower ends of the shelf sides (J), as shown in *Figure 8*. Screw through the shelf sides (J) into the ends of the bottom support (M), using two 2-1/2"-long screws on each of the joints.

Adding the Drawer

1. Cut two drawer sides (N) from 3/8" exterior plywood, each measuring 5 x 6-7/8 inches.

2. Cut two drawer glides (O) from 1 x 1 pine, each 7-1/4" long. To allow the drawers to slide without binding, plane or rip the drawer slides (O) on one side so they measure 1 1/16 x 3/4 inch.
3. Apply glue to the meeting surfaces, and attach one drawer glide (O) to one 6-7/8" edge of a drawer side (N), using three 1"-long finishing nails, as shown in *Figure 9*. Note that the drawer glide (O) extends past the drawer side (N) by 8/8" on one end.

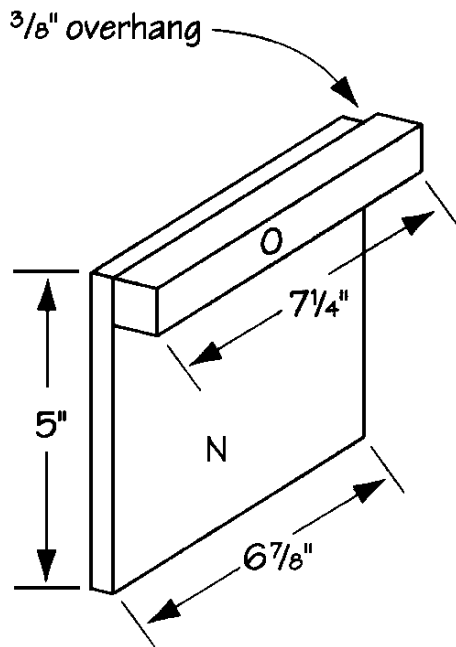

Figure 9

4. Repeat Step 3 to attach the remaining drawer glide (O) to the other drawer side (N). The 3/8" extension should be a mirror image of the one in Step 3.
5. Cut one drawer bottom (P) from 3/8" exterior plywood, measuring 14-1/2 x 6-7/8 inches.
6. Cut one drawer back (Q) from 3/8" exterior plywood, measuring 15-1/4" x 5".
7. Assemble the drawer bottom (P), drawer sides (N), and drawer back (Q), as shown in *Figure 10*, fitting the drawer back (Q) over the ends of the sides (N), and the drawer bottom (P) flush with the bottom edges of the drawer sides (N). Nail through the drawer sides (N) and drawer back (Q) into the edges of the drawer bottom (P). Use 1"-long finishing nails spaced about 3" apart.
8. Cut one drawer front (R) from 1 x 8 pine, measuring 18-3/4" long.
9. Rout the edges of the drawer front (R) with a round-over bit (optional) or simply sand the edges to slightly round them.
10. Attach the drawer front (R) to the drawer assembly. Center the drawer front (R) so that it is 3/4" above the drawer assembly at the top and extends 1" beyond each of the drawer glides (O), as shown in *Figure 10*. Nail through the drawer front into the ends of the drawer sides (N), drawer bottoms (P), and drawer glides (O), using 1-1/2"-long finishing nails. Use two nails on each joint.

Adding the Drawer Supports

1. The drawer supports are comprised of two pieces of wood glued together. We will assemble the two pieces first, and cut the resulting assembly to form two supports. Cut one horizontal drawer support (S) from 1 x 2 pine, measuring 22" long.

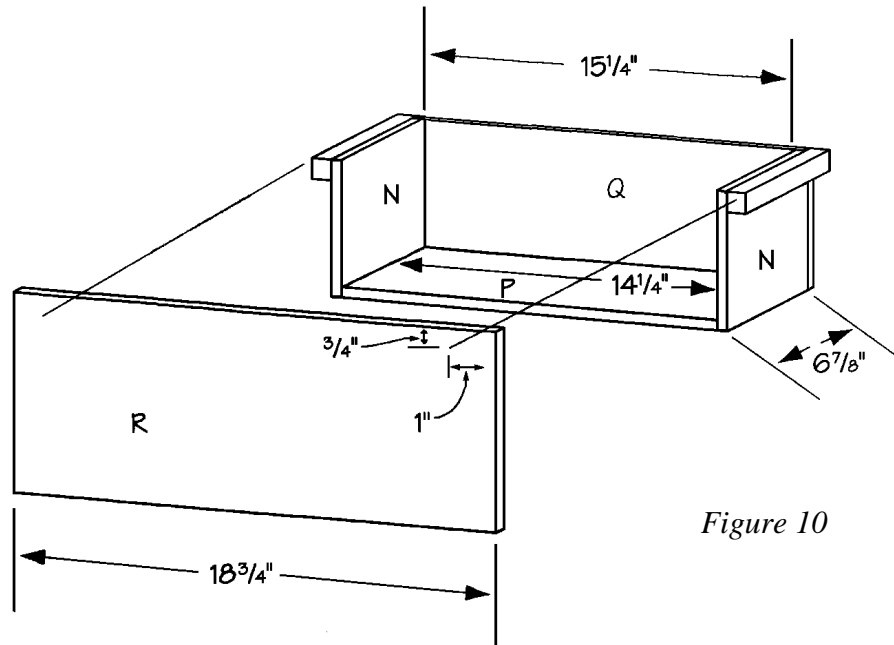

Figure 10

2. Cut one vertical drawer support (T) from 1 x 1 pine, measuring 22" long.
3. Apply glue to the meeting surfaces, and attach the vertical drawer support (T) to one edge of the horizontal support (S), as shown in *Figure 11*. Align the long edges accurately. Use 1-1/4" finishing nails, spacing them every 3 or 4 inches. Allow the glue to set up.

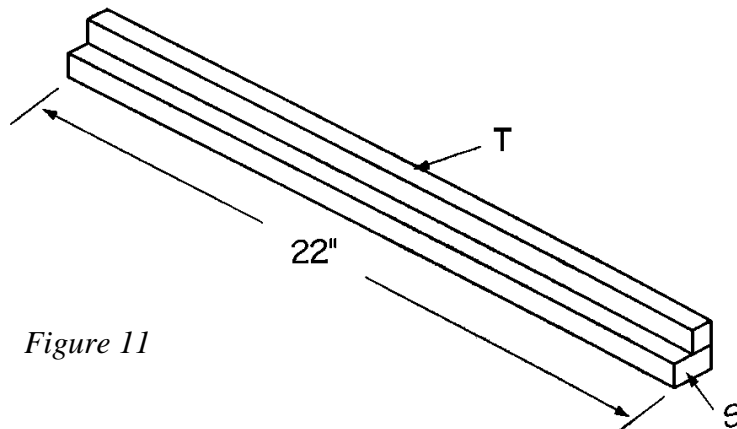

Figure 11

4. Cut two drawer supports from the glued support assembly, each measuring 7-1/4" long.
5. Mount one drawer support under the lower shelf (L), 1/2 from the right shelf side (J), as shown in *Figure 12*. Screw through the top of the shelf (L) into the drawer support, using two 1-14"-long screws.
6. Slide the drawer in place, and mark the placement of the second drawer support. Be sure to leave a little play in your measurements – you don't want to have to force the drawer open

and closed. Attach the second drawer support under the lower shelf following your placement marks.

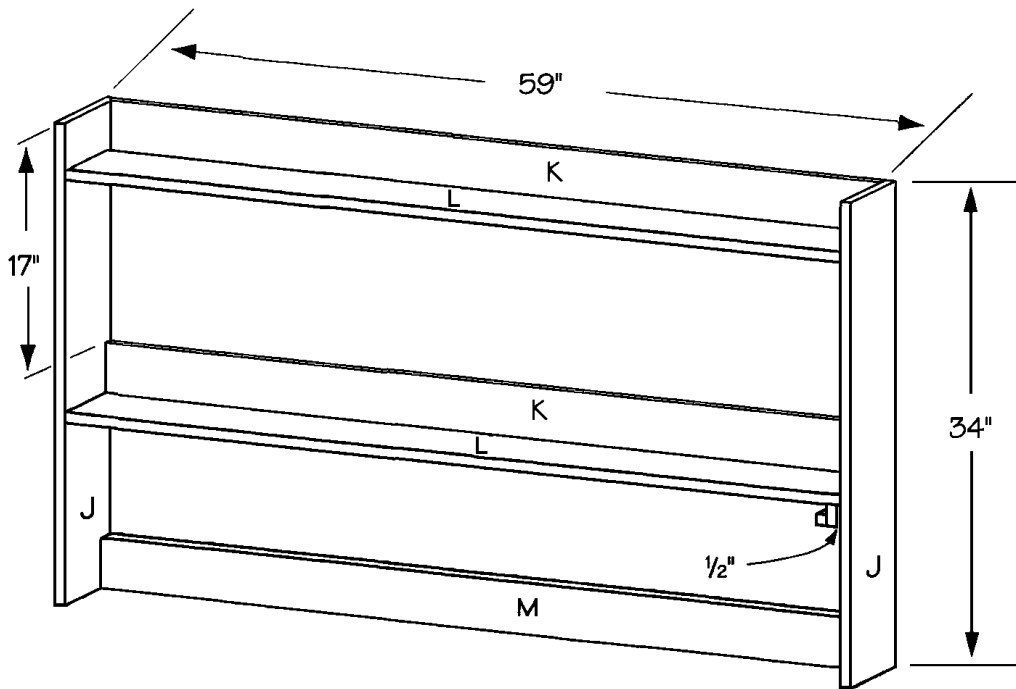

Figure 12

Attaching the Top Shelf Section

1. Cut two top supports (U) from 2 x 4 pine, each measuring 8" long.
2. Miter one end of each of the two top supports (U) at a 45-degree angle, as shown in *Figure 13*.

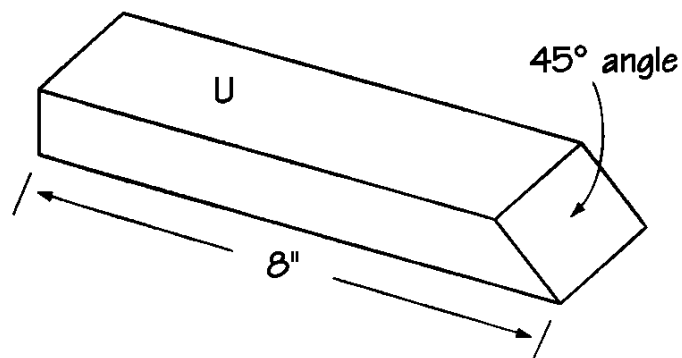

Figure 13

3. Apply glue to the meeting surfaces and attach the top supports to the back of the side supports on the lower section, against the rectangular top. Screw through the top supports (U) into the ends of the horizontal sides (A) and the edges of the vertical sides (B). Use two 2-1/2"-long screws on each joint.

4. Place the top shelf assembly over the bottom assembly, matching the sides and backs. To make the potting bench portable, we skipped the glue; that way, the two sections can be separated for transporting. Screw through the bench top (from underneath) into the bottom ends of the shelf sides (J). Use three 1-5/8"-long screws on each joint.

Finishing

1. We used a 6"-length of the remaining support assembly to fashion our drawer pull, and screwed it to the front of the drawer front using two 1-5/8"-long screws. You can use the same technique, or purchase a different drawer pull at the hardware store.
2. Fill any cracks, crevices, or screw holes with wood filler, and thoroughly sand all surfaces of the completed potting bench.
3. It is a good idea to seal the completed bench with an exterior grade sealer.

**Enjoy other indoor and outdoor projects from
www.wowimadeit.com!**

