

Littrow configuration tunable external cavity diode laser with fixed direction output beam

C. J. Hawthorn, K. P. Weber, and R. E. Scholten^{a)}

School of Physics, The University of Melbourne, Parkville Victoria 3052, Australia

(Received 12 June 2001; accepted for publication 14 September 2001)

We have developed an enhanced Littrow configuration extended cavity diode laser (ECDL) that can be tuned without changing the direction of the output beam. The output of a conventional Littrow ECDL is reflected from a plane mirror fixed parallel to the tuning diffraction grating. Using a free-space Michelson wavemeter to measure the laser wavelength, we can tune the laser over a range greater than 10 nm without any alteration of alignment. © 2001 American Institute of Physics. [DOI: 10.1063/1.1419217]

Extended cavity diode lasers are commonly used in many experiments in optical and atomic physics.^{1–5} These take advantage of efficient low-cost diode lasers, and use frequency selective feedback to achieve narrow linewidth and tunability. Frequency selective feedback is typically achieved via diffraction gratings in either the Littrow^{6–8} or Littman–Metcalfe configurations.^{9,10}

In the more common Littrow configuration, first-order diffraction from the grating is coupled back into the laser diode, and the directly reflected light forms the output beam. This particularly simple and effective configuration can be used with inefficient gratings to reduce the feedback and increase the output power, hence, improving overall efficiency.^{6–8} Unfortunately, the output beam direction is wavelength dependent, leading to alignment problems when tuning the laser. This can be circumvented by using an intracavity beamsplitter as an output coupler,^{4,11,12} but it is difficult to avoid losses via direct reflection of a second output beam from the grating, and the beamsplitter must be of high quality to minimize losses and prevent secondary cavity formation.

The Littman–Metcalfe design uses a grating at near grazing incidence, with the first-order diffracted beam reflected back to the grating and diode laser by an additional mirror. The wavelength in this case is selected by the mirror angle, so that the grating and the zeroth-order reflected output beam remain fixed with wavelength.⁹ Compared to the Littrow arrangement, this design is more complex, requires a larger grating and an additional mirror, and typically has lower output efficiency.

We demonstrate a very simple modification to Littrow configured extended cavity diode lasers (ECDLs) to produce a fixed direction output beam, with negligible expense in output power, and avoiding intracavity optics. We refer to the popular ECDL design of Arnold, Wilson, and Boshier⁶ (Fig. 1), though our modifications can also be applied to other arrangements.^{4,7,8} The ECDL consists of a laser diode and aspheric collimating lens ($f=4.5$ mm 0.55 NA, Thorlabs C230TM-B) mounted in a collimation tube (Thorlabs

LT230P5-B) fixed to a modified mirror mount (Newport U100-P). Our tuning diffraction grating is gold coated, with 1800 lines/mm on a $15\times 15\times 3$ mm³ substrate (Richardson Grating Laboratory 3301FL-330H). Typical diffraction efficiency is about 15% with up to 80% directly reflected to form the output beam. The grating is attached to the front face of the modified U100-P, which provides vertical and horizontal grating adjustment. A 1-mm-thick PZT piezoelectric transducer disk under the grating is used to modify the cavity length for fine frequency tuning, and may also be used to dither the frequency for an ac locking system. A temperature sensor (10 k Ω thermistor) and Peltier thermoelectric cooler (Melcor CP1.4-71-045L, $30\times 30\times 3.3$ mm³) are used for temperature control. Our lasers typically produce 40 mW at 780 nm using 70 mW Sanyo diodes (DL-7140-201). Their linewidth is better than 400 kHz and the lasers remain locked to a saturated absorption peak in a Rb vapor cell for hours or days. The wavelength can be tuned discontinuously over a 10 nm range by rotation of the grating alone, and over a wider range with suitable temperature adjustment.

Our main modification is the addition of a single plane mirror, fixed relative to the tuning diffraction grating with a simple mount (Fig. 2) attached rigidly to the arm of the existing laser by two screws. The laser beam reflects from the grating and then from the mirror. As the grating is rotated by $\Delta\theta$, the beam reflected by the grating is deflected by twice that angle, $2\Delta\theta$. Since the mirror rotates by the same amount, when this beam is then reflected by the mirror, it is deflected back by $2\Delta\theta$, so that the output beam direction remains constant. The mirror is conveniently arranged parallel to and facing the grating, but their relative angle does not affect the directional stability of the output beam.

We have found a more elaborate version of this scheme described for use with CO₂ lasers some 30 years ago.¹³ Our design for ECDLs is simpler and readily applied to laser systems now in widespread use. The compact nature of our arrangement is also advantageous. As the grating angle is altered, the relative position of the beam on the mirror also changes, introducing a small lateral shift in output beam position. For small changes in grating angle $\Delta\theta$, the output beam is displaced by $\Delta x \approx 2L\Delta\theta$, where L is the distance the

^{a)}Electronic mail: r.scholten@physics.unimelb.edu.au

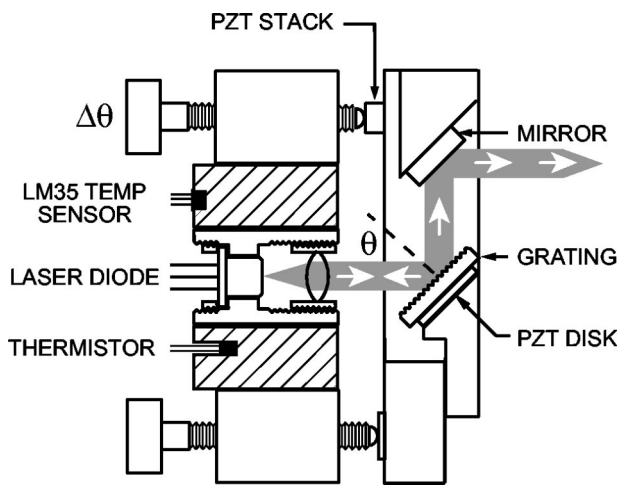

FIG. 1. Littrow configured ECDL with fixed output beam direction, based on the design of Arnold, Wilson, and Boshier (Ref. 6).

beam travels between the grating and the mirror. For a tuning range of 1 GHz, typical for tuning through an atomic resonance or during laser cooling studies, and $L = 15$ mm, the displacement is only 80 nm. This is insignificant for most applications.

Small shifts can be corrected by translating the grating with a dc voltage on the existing piezodisk, typically about 200 V for 80 nm. Larger displacements can be corrected by manually translating the mirror or grating, or using external optical elements. For example, the output beam could be passed through a tilted optical flat, rotated appropriately to correct the lateral beam shift. Alternatively, the output beam can be reflected from another mirror fixed to a linear translator.¹³ A particularly elegant solution to the problem uses a dihedral configuration of grating and mirror: by rotating both grating and mirror about a pivot point at the intersection of their surface planes, the output beam is fixed in both direction and displacement.¹⁴ Unfortunately, this cannot be achieved using commercially available mirror mounts of the type used here.

Figure 1 also shows additional modifications to the previous design,⁶ in particular, the addition of a stacked piezoelectric transducer (Tokin AE0203D04). The piezostack drives the grating-mirror pivot arm, and hence the grating angle, allowing electronic wavelength adjustment of 20 GHz over the 100 V range of the stack. To prevent fracture of the

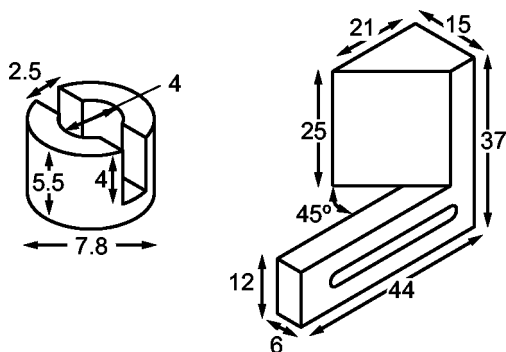

FIG. 2. Details of brass cap for the piezostack and aluminum mount for the additional mirror. Note the different scales; dimensions are shown in mm.

stack from the high pressure at the ball end of the adjustment screw, it is protected with a small brass cap as shown in Fig. 2. The piezodisk is used for frequency feedback locking to an atomic transition, but the broad frequency off-set adjustment provided by the stack reduces the voltage range required on the disk, below the 1000 V used in the original design.⁶ Indeed, the lasers lock well even when the disk is operated within the standard range of low-voltage analog electronics (0–15 V). The laser frequency noise is strongly affected by electrical noise on the stack supply due to the high-voltage sensitivity of the stack (0.2 MHz per mV). With low-pass passive filtering of the stack voltage, two identical lasers were locked to Zeeman-dithered atomic resonances in rubidium,¹⁵ and the rf beat between them observed with a fast photodiode. We measured a combined width of 525 kHz, averaged over 100 s, corresponding to individual laser linewidths of 370 kHz.

In addition to the thermistor used for temperature control, an LM35 semiconductor sensor on the collimation tube provides independent readout, isolated from the temperature controller circuit, with a simple 10 mV/°C calibration.

Several further improvements (not shown) include a laser diode protection board with passive filtering to remove current transients and a relay that trips to short the laser when not in use or when the power cable is disconnected. Our lasers are mounted to a heavy (5 kg) metal base to provide inertial and thermal damping. The base is isolated from the optical bench by a thick layer of inelastic polymer (Sorbothane) and enclosed with an aluminum cover, which is also isolated from the laser by strips of Sorbothane. This shields the laser from air currents, improves temperature stability, and further dampens acoustic vibrations.

The output beam directional stability was demonstrated by monitoring the wavelength in real time as the grating angle was adjusted, using a Michelson wavemeter¹⁶ located 1.5 m from the laser. Despite the high sensitivity of the wavemeter to angular misalignment, we were able to track the change in wavelength over the maximum laser tuning range of 10.5 nm without the need for any realignment. This wavelength change would normally shift the output direction of the laser beam by 1.2°, and cause a displacement at the wavemeter of 3 cm. With the additional mirror, the angle was unchanged, and the lateral shift was negligible (0.4 mm).

In conclusion, the simple modifications described here can easily be made to many existing Littrow configuration external cavity diode lasers, greatly enhancing their ease of use in many laser cooling, spectroscopy, and other atomic physics experiments.

The authors would like to thank P. J. Fox, M. R. Walkiewicz, and L. D. Turner for their assistance with the design and construction of associated electronics and vibration isolation. The authors acknowledge the support of the Australian Research Council, and the Australian Postgraduate Research Awards scheme for two of the authors (C.J.H. and K.P.W.).

¹M. W. Fleming and A. Mooradian, *IEEE J. Quantum Electron.* **QE-17**, 44 (1981).

²R. Wyatt and W. J. Devlin, *Electron. Lett.* **19**, 110 (1983).

- ³C. E. Wieman and L. Hollberg, *Rev. Sci. Instrum.* **62**, 1 (1991).
- ⁴K. B. MacAdam, A. Steinbach, and C. Weiman, *Am. J. Phys.* **60**, 1098 (1992).
- ⁵K. G. Libbrecht, R. A. Boyd, P. A. Williams, T. L. Gustavson, and D. K. Kim, *Am. J. Phys.* **63**, 1 (1995).
- ⁶A. S. Arnold, J. S. Wilson, and M. G. Boshier, *Rev. Sci. Instrum.* **69**, 1236 (1998).
- ⁷L. Ricci, M. Weidemuller, T. Esslinger, A. Hemmerich, C. Zimmermann, V. Vuletic, W. Konig, and T. W. Hansch, *Opt. Commun.* **117**, 541 (1995).
- ⁸T. Hof, D. Fick, and H. J. Jansch, *Opt. Commun.* **124**, 283 (1996).
- ⁹K. C. Harvey and C. J. Myatt, *Opt. Lett.* **16**, 910 (1991).
- ¹⁰S. Lecomte, E. Fretel, G. Mileti, and P. Thomann, *Appl. Opt.* **39**, 1426 (2000).
- ¹¹M. G. Boshier, D. Berkeland, E. A. Hinds, and V. Sandoghdar, *Opt. Commun.* **85**, 355 (1991).
- ¹²G. M. Tino, M. de Angelis, F. Marin, and M. Inguscio, in *Solid State Lasers: New Developments and Applications*, edited by M. Inguscio and R. Wallenstein (Plenum, New York, 1993), pp. 287–303.
- ¹³B. J. Orr, *J. Phys. E* **6**, 426 (1973).
- ¹⁴T. M. Hard, *Appl. Opt.* **9**, 1825 (1970).
- ¹⁵T. P. Dinneen, C. D. Wallace, and P. L. Gould, *Opt. Commun.* **92**, 277 (1992).
- ¹⁶P. J. Fox, R. E. Scholten, M. R. Walkiewicz, and R. E. Drullinger, *Am. J. Phys.* **67**, 624 (1999).