

**How To**  
**Select The**  
**Right**  
**Laboratory**  
**Hood System**



*Protecting your  
laboratory environment*

**LABCONCO**

**An Industry Service Publication**

## Foreword

This booklet has been developed to serve as an aid in selecting a laboratory fume hood ventilation system. The information is intended to be unbiased and generic in nature, compiled with help from experienced architects, laboratory consultants, engineers and laboratory hood users. The basic understanding of hood systems you gain from reviewing this booklet should prove valuable to you as you discuss your needs with safety officers, engineers and hood manufacturers.

## Our Method

The table of contents outlines the various issues which are addressed in this booklet. As you read through the material, remember you are selecting a laboratory hood system. A fume hood does not function alone. A variety of factors external to a hood influences its performance. Likewise, a hood and the applications performed inside it can also affect its surroundings. When selecting a fume hood, you must consider the whole picture — the laboratory space, the building's ventilation system, the hood's location in the room, to name a few.

While this booklet will raise the questions necessary to identify your specific hood requirements, it may not answer those questions. Only you, your safety officer or industrial hygienist, and a qualified design consultant can identify your laboratory's unique challenges.

We want this document to expand and improve over time. If you have suggestions for additions or improvements to this guide, please write Labconco Corporation, 8811 Prospect Avenue, Kansas City, MO 64132. Or call 800-821-5525 or 816-333-8811.

## Table of Contents

Page Number

<b>Selecting The Proper Enclosure</b>	
What is a Laboratory Fume Hood	3
<b>Laboratory Exhaust Systems and Types of Laboratory Hoods</b>	
Constant Volume — Conventional, By-Pass, Auxiliary-Air, Reduced Air Volume	3-4
Variable Air Volume	4
<b>Special Application Laboratory Fume Hoods</b>	
Perchloric Acid Hoods	5
Radioisotope Hoods	5
Distillation and Walk-In Hoods	5-6
<b>Not All Enclosures are Laboratory Hoods</b>	
Canopy Hoods	6
Downdraft Hoods	6
Ductless Carbon-Filtered Enclosures	7
Biological Safety Cabinets and Other HEPA-Filtered Enclosures	7
Clean Benches	7-8
Glove Boxes	8
<b>Laboratory Hood Specifications</b>	
Hood Size	8
Liner Material	8-9
Sashes	8-9
Explosion-Proof vs. Non Explosion-Proof Hoods	10
Service Fixtures	10
Electrical Receptacles	10
Lighting	10
Americans with Disabilities Act Requirements	10-11
<b>Performance and Installation Considerations</b>	
Face Velocity and Containment Issues	11
Proper Techniques for Hood Use	12
<b>Ventilation System Components and Accessories</b>	
Remote Blowers	12-13
Blower Sizing	13
Integral Motor/Blowers	13
Airflow Monitor	14
Exhaust Air Treatment	14
Ductwork	15
Base Cabinets	15
Work Surfaces	15
Sash Stops	16
By-Pass Blocks	16
Sash Position Alarms	16
Fire Extinguishers	16
<b>Renovating Existing Laboratory Fume Hoods and Ductwork</b>	16
<b>Planning Laboratory Space</b>	
Laboratory Layout	16
Sufficient Room Air	17
Energy Conservation	17
Noise Control	17
<b>Conclusion</b>	17
<b>Laboratory Ventilation Standards</b>	17-18
<b>General References</b>	18
<b>Glossary</b>	19

## Selecting The Proper Enclosure

### What is a Laboratory Fume Hood?

A laboratory fume hood is a ventilated enclosure where harmful or toxic fumes or vapors can be handled safely. The purpose of the hood is to capture, contain and remove contaminants, preventing their escape into the laboratory. This is accomplished by drawing contaminants within the hood's work area away from the operator, so that inhalation and contact are minimized.



Protector® 60 Fiberglass Laboratory Fume Hood

Airflow into the hood is achieved by an exhaust blower which “pulls” air from the laboratory room into and through the hood and exhaust system. This “pull” at the opening of the hood is measured as face velocity. A baffle, air foil and other aerodynamically designed components control the pattern of air moving into and through the hood. Contaminated air within the hood is then diluted with room air and exhausted through the hood's duct system to the outside where it can be adequately dispersed at an acceptably low concentration.

## Laboratory Exhaust Systems and Types of Laboratory Hoods

All laboratory fume hoods' operational airflow can be described as one of two types: conventional and by-pass. Auxiliary-air and reduced air volume hoods are variations of the by-pass hood. Hoods use one of two kinds of exhaust systems: constant volume or variable air volume.

### Constant Volume

#### Conventional

The conventional hood is a basic enclosure with an interior baffle and movable front sash. The conventional hood generally operates at a constant exhaust

volume with the majority of exhaust air entering the hood through the sash opening. Closing the sash increases the speed of the air through the sash opening so that high face velocities are to be expected with the sash in the near closed position (Figure 1).

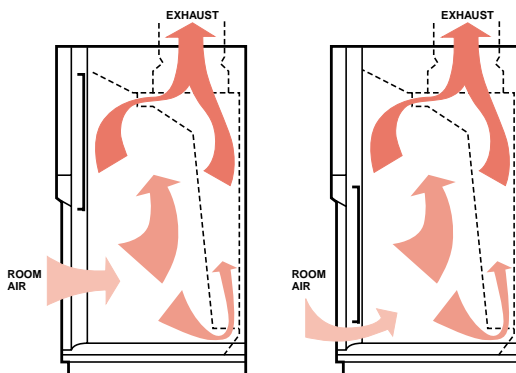

Figure 1. Conventional hood with sash open and nearly closed

The conventional hood is generally the least expensive, but its performance depends largely on sash position. With the sash in the near closed position, high velocity air passing through the sash opening can damage fragile apparatus, disturb instrumentation, slow distillation rates, cool hot plates, disperse valuable sample materials or result in turbulence inside the hood.

#### By-Pass

The by-pass hood generally operates at a constant volume and is designed so that as the sash is closed, the air entering the hood is redistributed, thereby minimizing the high velocity air streams encountered in conventional hoods. The by-pass openings above and below the sash area reduce fluctuations in face velocity as the sash is raised or lowered (Figure 2). Therefore, the face velocity in by-pass hoods does not generally reach levels which might be detrimental to lab fume hood procedures. By-pass type hoods comprise the majority of hoods on the market.

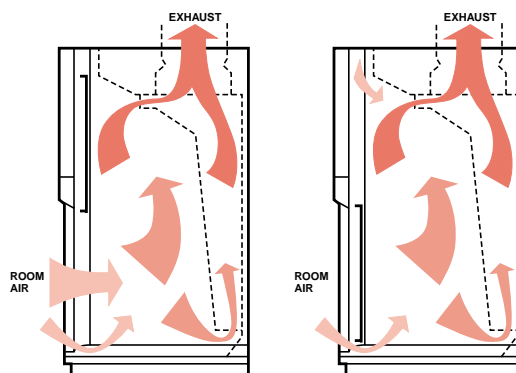

Figure 2. By-pass hood with sash open and closed

### Auxiliary-Air

A variation of the by-pass hood, the auxiliary-air hood offers a means of providing up to 50% of the air for the hood exhaust from outside the laboratory, and limits the volume of tempered air removed from the laboratory (Figure 3). This hood type has many names including induced air, add-air, balanced air and make-up air.

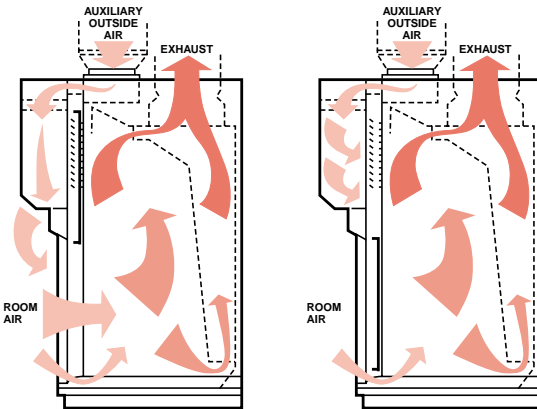

Figure 3. Auxiliary-air hood with sash open and closed

One advantage to auxiliary air hoods is that they feed air-starved laboratories, where room supply air volume is not adequate to support a laboratory hood. Another advantage to auxiliary-air is that, when properly applied, it can provide energy savings by limiting the volume of heated or cooled room air exhausted by the hood. The level of savings depends on the degree to which the auxiliary air must be tempered.

Certain negative aspects of auxiliary-air hoods should be considered. Because two blowers and two duct runs are required, initial equipment and set-up costs are higher than average. Since an oversized auxiliary-air system may overpower the exhaust system, auxiliary-air systems require careful balancing to prevent undesirable turbulence at the face of the hood. In addition, temperature extremes, caused by untempered auxiliary air, can adversely affect the hood's containment ability and cause user discomfort. Finally, the auxiliary air should be clean, dry and tempered properly so it does not interfere with analytical work being done in the hood.

### Reduced Air Volume

A variation of the by-pass hood, the reduced air volume (RAV) hood uses a by-pass block to partially obstruct the by-pass opening above the sash to reduce the air volume exhausted thus conserving energy. It is used in conjunction with a sash stop that limits the height the sash may be opened during normal use so that the hood demands less air volume to achieve safe velocity. Since these hoods use less air

volume than by-pass hoods of the same size, they require smaller blowers, which can be another cost saving advantage.

RAV hoods should be used with caution. The sash stop should be overridden only when loading or cleaning the hood; never while in use. If the sash stop is disengaged and the sash raised while the hood is in use, the face velocity could drop to an unsafe level (Figure 4). A sash position alarm is recommended.

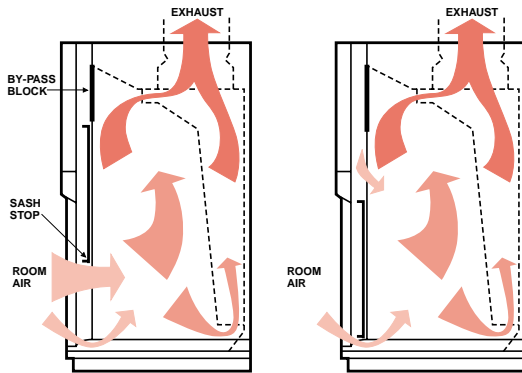

Figure 4. Reduced air volume hood with sash stop and by-pass block shown with sash open to sash stop position and sash closed

### Variable Air Volume

Variable air volume (VAV) hoods vary the amount of room air exhausted while maintaining the face velocity within a preset range. VAV hoods alter the exhaust volume using various methods. One method utilizes a damper that opens and closes based on airflow and sash position. Another method involves varying blower speed to meet air volume demands. When multiple hoods share one common exhaust blower, both methods may be utilized.

Fume hoods with VAV systems generally operate as conventional hoods. Some VAV hoods include a modified by-pass system which ensures that sufficient airflow is maintained to adequately contain and dilute fumes even at low sash positions (Figure 5).

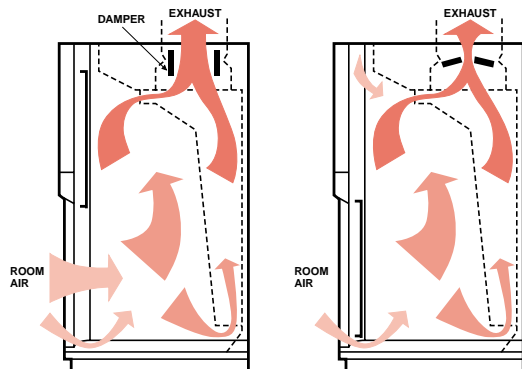

Figure 5. Variable air volume hood with damper control and modified by-pass

VAV systems are available built into the hood at the factory or as an accessory added to the hood upon installation. Some VAV hoods have electronics which allow them to be connected to the laboratory building's heating, ventilation and air conditioning (HVAC) system for monitoring hood exhaust air and controlling laboratory air supply from a central location.

Although initial start up costs may be higher due to building alterations, VAV hoods offer energy savings over traditional by-pass and auxiliary-air hoods. At the same time, they offer consistent airflow regardless of sash position so they are a good choice for complicated or lengthy experiments. In addition, most VAV systems feature monitors/alarms which alert the operator to unsafe airflow conditions.

## Special Application Laboratory Fume Hoods

Unique features may be added to the hood and exhaust system to accommodate special procedures in the hood. Below are descriptions of a few of the many special purpose hoods on the market.

### *Perchloric Acid Hoods*

Perchloric acid hoods are dedicated for use with perchloric acid only. Organic materials should not be used in a perchloric acid hood because an explosion may occur when perchloric acid reacts with organic materials. It must be constructed of relatively inert, impervious materials such as Type 316 stainless steel, Type 1 unplasticized polyvinyl chloride (PVC) or ceramic-coated material. Hoods used for these applications have integral work surfaces, covered interiors, and a drain for easy and thorough cleaning. Washdown features are required since the hood and duct system must be thoroughly rinsed after each use to prevent the accumulation of potentially reactive perchloric salts. (Figure 6). Horizontal duct runs and sharp turns should be avoided so that washdown residue drains thoroughly. Each perchloric acid hood requires its own dedicated exhaust system with washdown capability.

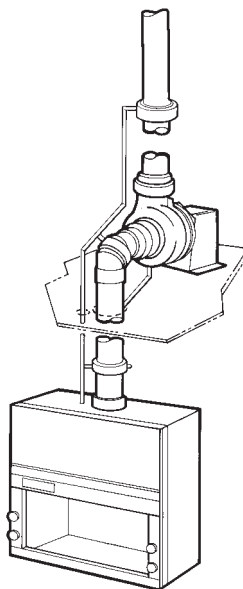

Figure 6. Perchloric acid hood with washdown system

### *Radioisotope Hoods*

Hoods used for radioactive applications have integral work surfaces and covered interiors to facilitate decontamination. Liner materials, such as Type 304 stainless steel, should be impermeable to radioactive materials. Cupsinks are sometimes provided in the integral work surface, however local codes which dictate the safe disposal of radioactive effluents should be observed. These hoods should be sturdy enough to support lead shielding bricks in instances where they are required. They should also be installed to facilitate the use of high efficiency particulate air (HEPA) or charcoal filters in the ductwork. The laboratory's safety officer should determine which, if any, filters are required to trap the radioactive materials emitted during a particular application.

### *Distillation and Walk-In Hoods*

Distillation and walk-in hoods are constructed with additional interior height to accommodate large apparatus. Distillation hoods typically mount on a platform instead of a base cabinet or bench. A California hood is a type of distillation hood with sash entry on both sides (Figure 7). Walk-in hoods mount on the floor, permitting roll-in loading of heavy or bulk apparatus. Although called walk-in hoods, the operator should never stand inside the hood while fumes are being generated.



*Protector® 60 Fiberglass Walk-In Hood*

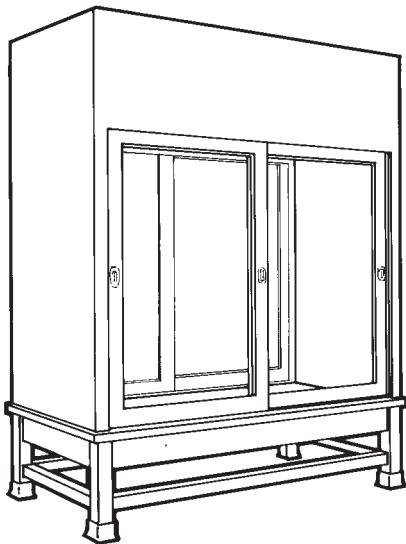

*Figure 7. California hood with front and back sashes*

## Not All Enclosures Are Laboratory Hoods

There are many enclosures designed to protect the operator from exposure to potentially hazardous substances. Other enclosures function to protect the samples contained inside. Although in some instances they may look similar to fume hoods, these containment devices have different modes of operation and different uses.

### Canopy Hoods

Canopy hoods are designed to remove steam, heat or odors from large or bulky apparatus such as ovens,

steam baths or autoclaves. Vapor removal is most efficient when the canopy is mounted no more than 12" above the equipment being ventilated. Because it is inefficient and ineffective in containing fumes, the canopy hood is not recommended for ventilating hazardous substances.



*Canopy Hood*

### Downdraft Hoods

Like fume hoods, downdraft hoods draw air into the face of the hood. Unlike fume hoods, the blower is usually mounted below the hood work area so that air is pulled down through a mesh work surface and then exhausted to the outside (Figure 8). Downdraft hoods are used for applications involving heavier than air gases and materials such as dusts and powders. In some cases, these materials are recovered for reuse.

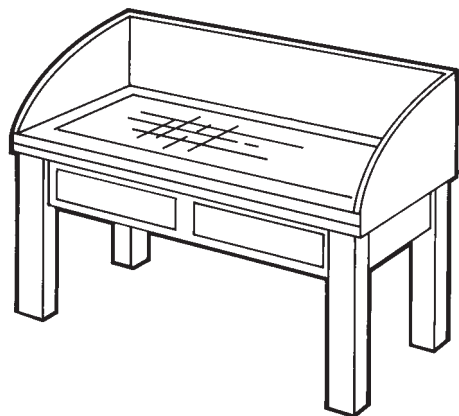

*Figure 8. A downdraft hood designed for removing powders generated by grinding metals or plastics*

### ***Ductless Carbon-Filtered Enclosures***

As the name implies, ductless enclosures are not connected to an exhaust system. They rely on filters to trap vapors and fumes before air is recirculated to the room. The filters are usually made of specially treated or activated charcoal media that treat or adsorb chemical fumes including certain organic solvents, ammonia, acids and formaldehyde. Filter types and capacities can vary widely between manufacturers. Since these enclosures recirculate filtered air back into the laboratory, they often have a built-in mechanism to alert the user to unsafe concentrations of chemicals detected in the exhaust area of the filters.

Filtered enclosures can provide a practical solution for laboratories where ducting may not be feasible. Due to the cost of replacing saturated filters, these enclosures are recommended for applications involving only small quantities of chemicals. Since different filters may be required for different chemicals, the enclosures are generally limited to repetitive applications and procedures involving a limited number of chemicals. Special consideration should be given if the chemical fume is highly toxic or carcinogenic. Careful and regular monitoring by a safety officer is essential to the safe operation of these enclosures.



*Paramount™ Filtered Enclosure*

### ***Biological Safety Cabinets and Other HEPA-Filtered Enclosures***

Although often referred to as “hoods,” Class II biological safety cabinets are not fume hoods. Biological safety cabinets are designed to contain hazardous particulates such as bacteria and viruses and often recirculate cabinet air back to the laboratory. Biological safety cabinets use HEPA filters to trap particles while any gaseous materials pass through

freely. When exhausted to the outside, they can accommodate trace amounts of toxic chemicals and radionuclides. If the work involves infectious or carcinogenic agents and personnel and product protection are required, then a biological safety cabinet is probably the enclosure of choice. Other HEPA-filtered enclosures, including Class I enclosures, that provide only personnel protection are designed for applications including weighing powders or handling asbestos. For an in-depth discussion on HEPA-filtered enclosures including Class II safety cabinets and Class I enclosures, request the publication, *Personnel and Product Protection: A Guide to Biosafety Enclosures*, by calling 800-821-5525 or 816-333-8811.



*Purifier® Class II Biological Safety Cabinet on Base Stand*

### ***Clean Benches***

Clean benches are devices which use a blower to force room air through a HEPA filter, and over a work surface. This vertical or horizontal laminar flow of filtered air protects the work from particulate contamination. The major limitation of clean benches is that they provide only product protection; the operator is constantly exposed to any aerosols generated by the work being performed. Consequently, hazardous materials should never be handled in a clean bench. Clean benches were developed as part

of “clean room” technology and are widely used in the electronics and pharmaceutical industries. They have also been successfully used in research laboratories for tissue culture and media preparation, and in hospitals and pharmacies for drug preparation.



*Purifier® Horizontal Clean Bench on Base Stand*

### **Glove Boxes**

Glove boxes consist of a sealed chamber with glove ports and gloves for handling materials inside, a viewing window for observing, and transfer chamber or door for loading and unloading. Because they provide a physical barrier between the operator and the substances inside, glove boxes are appropriate for applications that require the greatest protection against inhalation of substances used within them. Glove boxes for hazardous materials such as low level radioisotopes and carcinogens filter the chamber air prior to exhausting it through a duct system to the outside. Other glove boxes used for containing atmosphere-sensitive materials may or may not be ducted to the outside.



*Protector® Controlled Atmosphere Glove Box on Mobile Base Stand*

## **Laboratory Hood Specifications**

### **Hood Size**

The working space inside a laboratory hood is defined as that part of the hood interior where apparatus is set up and vapors are generated. This space normally extends from behind the plane of the sash(es) to the face of the baffle, and up from the work surface, 34" to 48". The working space required determines the width of the hood needed. One source recommends that 5 linear feet of hood space be provided for every two workers if they spend most of their time working with chemicals.

Laboratory hood sizes are commonly expressed by the outside width and not by working space. The most common hood widths are 3, 4, 5, 6 and 8 feet. Custom designed fume hoods may have widths up to 24 feet. The actual working space is approximately 5" to 10" less than the expressed width of the hood.

### **Liner Material**

The liner material selected should be durable and resist chemicals, heat and open flame. A description of common liner materials and their characteristics follows (Table 1). The best liner material for a hood should be determined by the applications, types and concentrations of chemicals that will be handled in the hood and exhaust system. Laboratory hood effluents may be classified generically as organic or inorganic chemical gases, vapors, fumes or smokes — and qualitatively as fume acids, alkalis, solvents or oils. Hood liners are subject to attack from such effluents by: (1) corrosion (the destruction of metal or other material by chemical or electrochemical action), (2) dissolution (a dissolving action to which coatings and plastics are subject), and (3) melting (occurs with certain plastics and coatings at elevated operating temperatures). The effect of any decontamination materials on the hood liner should also be considered.

Working temperatures inside the work space also affect the selection of liner materials. Certain codes and insurance underwriters have flame and smoke spread rating requirements which establish prescribed limits to applicable materials. Most local environmental authorities have codes which incorporate standards based on NFPA Standard No. 45, Fire Protection for Laboratories Using Chemicals.

### **Sashes**

Sashes provide some physical protection from splashes and reactions, and are transparent to allow viewing. Sashes rise vertically, slide horizontally or combine both horizontal and vertical characteristics



	Stain Resistance	Moisture Resistance	Chemical Resistance	Heat Resistance	Flame Resistance	Other Comments
Epoxy-coated steel	Good	Very good	Good	Very good	Good, but will char	Care must be taken to avoid damaging coating since corrosion can occur in damaged areas. Inexpensive.
Epoxy-resin	Good	Excellent	Excellent	Very good	Good	Not easily modified. Brittle, requires care in handling. Expensive.
Fiberglass reinforced polyester (FRP)	Good	Excellent	Very good for a wide range of acids, solvents and alkalis	Good	Good	Excellent light reflective properties. Moldable to eliminate seams and crevices. Easily modified. Moderately expensive.
Glass reinforced cement (GRC)	Fair	Fair	Very good for a wide range of acids, solvents and alkalis	Excellent	Excellent	Good sound-dampening qualities. Heavy. Inexpensive. Brittle, requires care in handling.
Polypropylene	Very good	Excellent	Excellent	Poor	Fire-retardant, but poor heat resistance	Easily modified. Poor heat resistance. Expensive.
Polyvinyl chloride (PVC)	Very good	Excellent	Excellent except for some solvents	Poor. Will distort at 160° F	Fire-retardant, but poor heat resistance	Easily modified. Well-suited for sulfuric and acid hydrofluoric digestions. Expensive.
Solid composite panel	Good	Excellent	Excellent	Very good	Excellent	Excellent light reflective properties. Well-suited for corrosive materials. Moderately expensive.
Stainless steel (Type 316 or 304)	Good	Excellent	Good resistance to a wide range, subject to attack by some acids	Excellent	Excellent	Primarily used for special applications involving perchloric acid or radioisotopes. Heavy. Difficult to modify. Expensive.

Table 1. Hood liner materials

in a design known as an “A-style” sash (Figures 9, 10 and 11). Sash configuration selection is a matter of preference. Vertical rising sashes are the most popular and allow large apparatus to be loaded in the hood. Horizontal sliding sashes allow the operator to reach around both sides of the sash while using the sash as a shield. Because the sash opening is

smaller, they conserve energy by limiting the volume of air exhausted.

Safety glass is the most common and economical choice for sash material. Polycarbonate sashes are recommended when hydrofluoric (HF) acid is used since this material does not fog or etch when exposed to HF fumes.

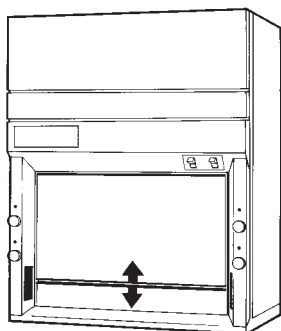

Figure 9. Hood with vertical-rising sash

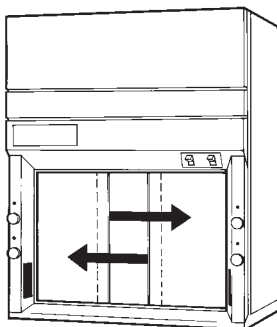

Figure 10. Hood with horizontal-sliding sashes

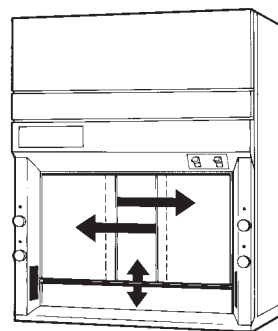

Figure 11. Hood with combination “A-style” sash

### Explosion-Proof vs. Non Explosion-Proof Hoods

An explosion-proof hood may be required for protection when specific concentrations of flammable or explosive materials are to be used. An explosion-proof hood is defined by most manufacturers as a laboratory hood equipped with specially designed electrical components, such as explosion-proof light fixtures. Explosion-proof does not mean that the hood is capable of containing or withstanding an explosion. Rather it means that electrical components are designed to eliminate sparks and prevent the escape of flame or heat that could ignite flammable materials. An explosion-proof hood's electrical components, such as explosion-proof switches, receptacles and internal wiring, are supplied and installed on site by a licensed electrician in order to meet all state and local codes. In addition to the components on the hood, the electrical apparatus used inside the hood should also be explosion-proof by design. The National Electrical Code can provide details about specific explosion-proof components.

### Service Fixtures

Utility services include connections to gases, air, water and vacuum (Figure 12). If service fixtures are required, they should be installed to allow the connection of service supply lines either on the hood itself or the work surface supporting the hood. All service valves should be accessible for maintenance and should be corrosion resistant if located inside the hood. The plumbing tubing should be of the proper material to satisfy local code requirements. For example, some states require gas service connections to be made with black iron pipe or tin-lined copper tubing. For safety and convenience, all service fixtures should be remotely controlled from outside the hood and clearly identified.

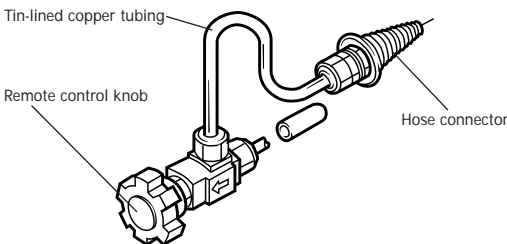

Figure 12. Components of a gas service fixture

### Electrical Receptacles

If electrical receptacles are required, they are usually located on the hood exterior, away from the corrosive effects of the fumes inside the hood structure (Figure 13). Provisions should be made so that all

electrical wiring is isolated and physically separated from vapors handled within the hood.

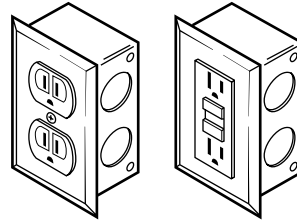

Figure 13. Duplex electrical receptacle

### Lighting

Light fixtures come in either vapor-proof or explosion-proof styles (Figure 14). Vapor-proof light fixtures are usually fluorescent, installed outside the hood liner and protected from the hood interior by a transparent, impact-resistant shield. Access for replacing or cleaning should be from the exterior, whenever possible. Explosion-proof lights are normally incandescent bulbs protected by a specially reinforced fixture mounted in the hood.

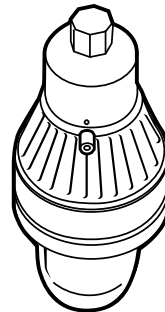

Figure 14. Explosion-proof light fixture protects incandescent bulb with globe and sealed housing

### Americans with Disabilities Act Requirements

Employers, except very small businesses, must comply with the Americans with Disabilities Act (ADA), a statute prohibiting discrimination against disabled individuals in employment. Fume hoods and accessories are available with features that meet the requirements of the ADA. Switches, controls and written instructions should be located where they can be seen and reached by a seated person. Hoods should have appropriate work surface height and clearance underneath to allow a person in a wheelchair to work comfortably. Audible alarms must have an intensity and frequency that can attract the attention of individuals who have partial hearing loss.



*Protector® Plus Laboratory Hood with low-mounted switches and controls meets ADA requirements*

## **Performance and Installation Considerations**

### ***Face Velocity and Containment Issues***

The laboratory's degree of exposure to toxic contaminants is an important consideration when selecting a fume hood. The concentration of contaminants in the actual breathing zone of the operator should be kept as low as possible. Two fume hood issues that impact the concentration of contaminants are face velocity and containment.

Regulatory compliance agencies and other advisory groups have established guidelines relating to the exposure limits of various chemical reagents. These exposure limits are identified as American Conference of Governmental Industrial Hygienists (ACGIH) Threshold Limit Values (TLV) or Occupational Safety and Health Administration (OSHA) Permissible Exposure Limits (PEL). Threshold Limit Values refer to airborne concentrations of substances and represent conditions under which it is believed workers may be repeatedly

exposed day after day without adverse effect. Until recently, general thinking was that the lower the TLV number, the higher the face velocity required to ensure adequate protection for the operator. Face velocity is still regarded as an important parameter for assessing a hood's performance. However, present views focus on containment rather than face velocity alone. Higher velocity is not necessarily better. A face velocity that is too high can cause turbulence within the hood and actually decrease the hood's ability to contain contaminants. Consult the latest edition of *Industrial Ventilation, A Manual of Recommended Practice*, published by the ACGIH for their guidelines on fume hood face velocities.

Factors that affect the performance level of the laboratory hood that are not easily monitored by simple measurement of face velocity include: 1) type and location of air supply; 2) location of laboratory hood in relationship to the laboratory itself; 3) air disturbances caused by overhead air diffusers, heat registers, fans, open windows or doors or personnel movement; 4) hood sash configurations; 5) location of the worker in relation to the hood; 6) location and types of emission sources; 7) apparatus loaded or stored in the hood; 8) use of apparatus such as machine tools, grinders or centrifuges that generate aerosols and/or high velocity particles; and 9) thermal drafts due to extreme temperature conditions.

Because of these external demands, the American Society of Heating, Refrigerating and Air-Conditioning Engineers (ASHRAE) Standard 110-95 was developed to demonstrate the laboratory hood's ability to contain and exhaust contaminants released inside the hood.

ASHRAE Standard 110-95 is a performance test, not a performance specification. It describes how to evaluate a hood's performance, but it does not specify the performance level required. It remains the responsibility of the user, industrial hygienist, safety officer or applications engineer to specify the performance level requirement for a laboratory's individual situations.

ASHRAE Standard 110-95 gives a relative and quantitative determination of the efficiency of the hood to capture contaminants under a set of strict conditions. This test is used to evaluate hoods, both in the manufacturer's facility (as manufactured, AM), and on site (as installed, AI, or as used, AU).

Briefly, ASHRAE Standard 110-95 is a three part test. First, the average face velocity is calculated. The sash opening is divided into one-foot squares. Velocity readings are taken in each grid area and averaged (Figure 15).

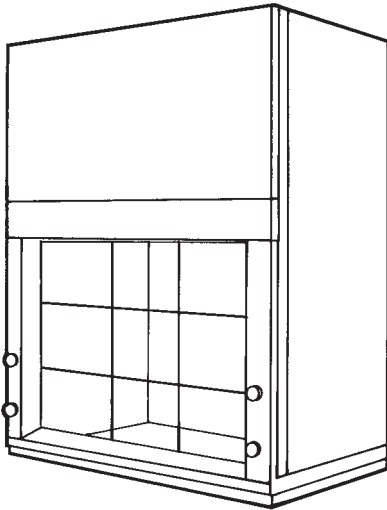

Figure 15. One-foot square grid pattern for velocity readings

Second, the hood is tested for its ability to contain fumes. Titanium tetrachloride, which emits a white smoke, is released at prescribed locations within the hood's interior and work surface. Smoke is observed and any air movement toward the face of the hood and any areas of no air movement are noted. Titanium tetrachloride is also passed under the air foil and any smoke flowing out the front is noted.

In the final part of the test, a tracer gas is released at an established rate and at various positions within the hood. The gas is monitored in the breathing zone of a mannequin placed at various positions in front of the hood. Based on the average exposure in the breathing zone, a performance rating is determined. The complete standard is available from ASHRAE.

It is recommended that laboratory hoods be tested at the time of installation to verify the AM test results. Initial testing provides a baseline for future maintenance checks. Hood performance should be evaluated routinely to ensure safe operation.

### Proper Techniques for Hood Use

Containment and efficient removal of fumes are enhanced when the operator follows proper hood procedures. Apparatus should be placed at least six inches inside the hood. Large apparatus that can obstruct airflow should be elevated on blocks to allow fumes to pass under them. The hood should not be used as a storage cabinet; equipment in the hood should be kept to a minimum so airflow is not compromised. Finally, the sash should be closed as much as possible when work is being performed inside the hood. *The Industrial Ventilation Manual* may be referenced for a complete list of recommendations for proper operator techniques.

### Ventilation System Components and Accessories

The laboratory hood is just one component of a complete fume ventilation system. At the same time a hood is selected, a blower, ductwork, base cabinet and work surface must also be selected (Figure 16). Air supply must be determined as well. A laboratory fume hood may, as appropriate, also include an air-flow monitor, filtration system and fire extinguisher.

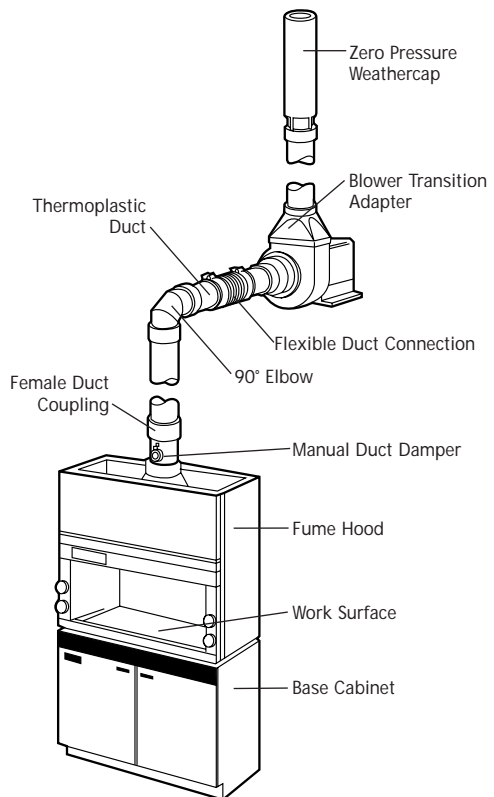

Figure 16. Typical components of a hood ventilation system

### Remote Blowers

Of all the additional components needed, the blower is the most crucial to the performance of the hood. Fume hood installations utilizing remote blowers are the most common type. Since the entire duct length is under negative air pressure, any leakage in the duct is drawn in and contained rather than pushed out into the building environment. The exhaust blower is positioned in a penthouse or on the building's exterior, usually on the roof, where noise is less noticeable. By creating suction within the ductwork, blowers draw air from the laboratory room, through the hood and out the duct system.

Centrifugal type blowers are popular because they are more efficient and less noisy than others. Belt-driven impellers have greater flexibility than direct-drive impellers because the belt can be



*Labconco Fiberglass Blower, a centrifugal blower with belt-driven impeller*

adjusted to vary the air volume. Blower components are constructed from a variety of materials. To resist corrosion from chemical fumes, impellers may be made of various types of steel or plastic. For weatherproofing when roof-mounted, blowers have protective housings. Blowers used to exhaust potentially flammable materials should be explosion-proof, meaning the blowers' components are designed to contain a spark and prevent the escape of flame or heat that could ignite a flammable atmosphere.

In addition to centrifugal blowers, other exhaust devices are available including air ejectors (Figure 17). An air ejector creates suction by venturi method to draw fumes through the ductwork. Air ejectors are suitable for use with highly corrosive fumes, such as perchloric acid, because the blower wheel never comes into contact with the fumes. Air ejectors are considerably more expensive and noisier than centrifugal type blowers.

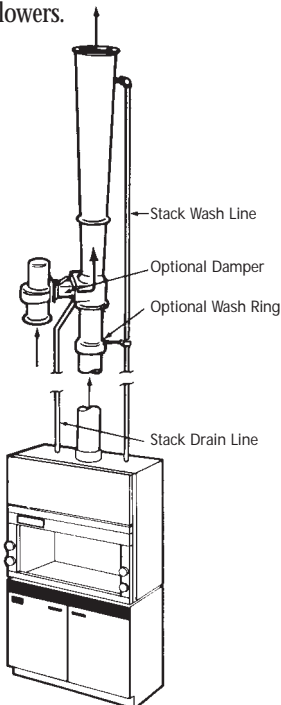

*Figure 17. Air ejector installed with washdown system*

### **Blower Sizing**

To provide the optimum face velocity and air volume for the laboratory hood, the blower must be sized properly. Although horsepower and revolutions per minute (RPM) are important blower specifications, blower selection should be based on the air volume the hood will exhaust and the total static pressure loss of the entire system.

### **Air Volume**

The air volume passing through the hood is generally equal to the area of the sash opening multiplied by the average velocity desired. For example, if 100 feet per minute (fpm) is required and the hood has a sash opening of 7.5 square feet, then the hood's air volume is 750 (7.5 x 100) cubic feet per minute (CFM).

### **Static Pressure Loss**

At any given exhaust volume, the hood has a unique static pressure loss usually expressed in inches of water. The manufacturer can provide this static pressure loss information. In addition, the ductwork components (duct, elbows, reducers, weathercaps) and filters in the system have static pressure losses based on the volume of air passing through them, which is often expressed as equivalent resistance in feet of straight duct. To determine the total pressure loss in the ductwork, the equivalent resistance in feet of straight duct for all the components in the system is totaled. This total equivalent feet provides a method to calculate the static pressure loss at specific air volumes. The static pressure loss of the ductwork is added to the static pressure losses of the hood and any filters for the total static pressure loss of the system.

### **Integral Motor/Blowers**

Some fume hoods are available with motors and blowers built directly into the hood superstructure (Figure 18). These hoods are relatively easy and inexpensive to install. However, a built-in blower should not be used for corrosive or highly toxic applications since it causes positive air pressure in the duct system, and any leaks could push contaminants out of the ductwork. This type of hood may be more noisy since the blower is closer to the user. Long duct runs, too, may prohibit its use since these blowers are sized to fit a narrow range of static pressure requirements. The manufacturer can provide duct length parameters for its laboratory hoods with built-in blowers.

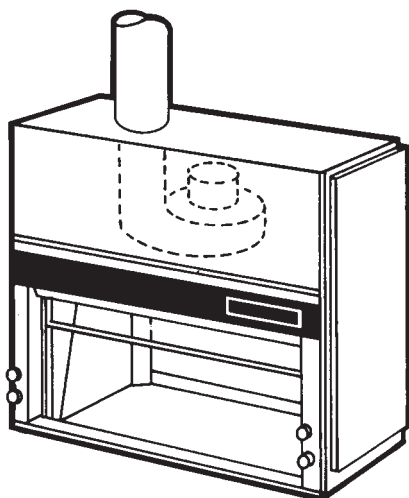

Figure 18. Hood with integral motor/blower

### Airflow Monitor

American National Standards Institute (ANSI) Standard Z9.5 requires the use of an airflow monitor, a device that gives warning (by a visible or audible signal, or both) when the airflow through the hood has deviated from a predetermined level. When mounted in an easily accessible area, monitors may have locking devices to prevent tampering by unauthorized personnel. Other monitors include a remote alarm signal and/or automatic auxiliary-air/exhaust blower interlock which shuts off the auxiliary-air blower should the exhaust blower fail.



Guardian™ Jr. Airflow Monitor

### Exhaust Air Treatment

Depending on the hazard level associated with the laboratory operation, and the degree of pollution abatement required, treatment for the hood's effluents may be necessary. Treatment methods include

filtering, wet scrubbing and incineration, each effective for a specific range of materials. No universal treatment exists.

Dry media filters (95% efficient by ASHRAE Standard 52-68 Test Method) or HEPA filters (99.97% efficient by DOP Test Method) may be required to meet specified design criteria (Figure 19). The filter assembly may include a prefilter for capturing coarse particles and a filter enclosure arranged for easy access. For removing gaseous organic compounds, activated charcoal filters are often satisfactory. Many filters are not suitable for collecting radioisotopes. Consult a reputable filter manufacturer for specific recommendations.

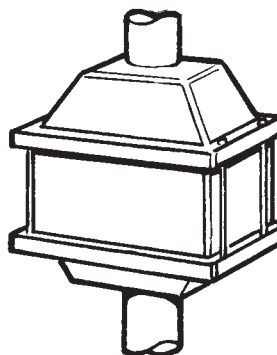

Figure 19. HEPA filter with housing designed for in-line connection to duct system

For convenient handling, replacement and disposal with minimum hazard to personnel, the filter should be: (1) located outside the laboratory area unless it is an integral part of the hood; (2) ahead of the exhaust blower; and (3) installed in space that provides free, unobstructed access. The filter should be located on the suction side of the exhaust blower and as close to the laboratory as possible to minimize the length of contaminated ductwork. Some installations will require shut-off dampers and hardware for filter decontamination in the ductwork. A damper is often added to filtered hoods to balance airflow because HEPA filters vary and change in airflow resistance as they load during use.

The filter housing should provide easy transfer of the contaminated filter to a disposal site. Depending on the nature of the work, the filter may need to be treated as hazardous waste. Local codes should be consulted for regulations on disposal.

Fume scrubbers are another type of device placed in the hood or in the fume duct system to remove particulates and soluble contaminants from exhaust air. Scrubbers use water or chemical sprays to remove particulates and to neutralize and dilute acids or alkaline materials (Figure 20). Scrubbers may have a filtering system to trap particulates.

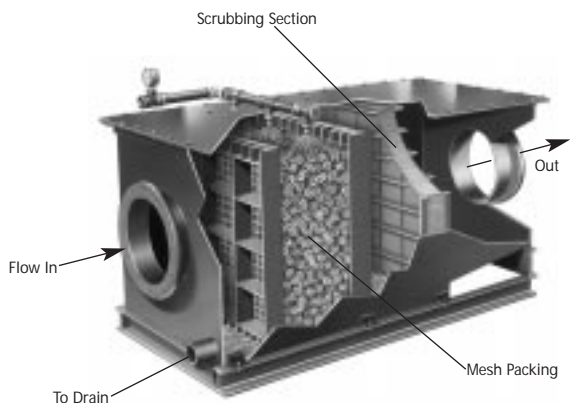

Figure 20. Swirlaway® Fume Scrubber utilizing water spray

### Ductwork

Ductwork includes fume pipe, male and female couplings, elbows, reducers and exhaust discharge stacks (weathercaps). Round diameter duct made of rigid materials offers the least static resistance. Like the liner material of a laboratory hood, duct material must be resistant to the fumes exhausted through it. Ductwork made of unplasticized polyvinyl chloride (PVC) is a popular choice because it is rigid, highly resistant to both acid and solvent vapors and, because it is extruded, comes in round diameters. Stainless steel and coated steel are used when very high temperatures are anticipated and because they offer fire protection. Fiberglass provides high structural strength and corrosion resistance. Local codes should be consulted for duct material recommendations.



Round PVC pipe with female coupling



90-Degree PVC elbow

### Base Cabinets

Most laboratory hoods are designed to rest on a bench-high base stand or cabinet with a work surface. Existing casework may be used as long as it provides adequate depth and height for the structural support of the hood. Base stands that allow the users to be in the sitting position may be preferable for persons with limited mobility. Specialty base cabinets are available that store acids or solvents. If base cabinets are vented into a laboratory hood, they will be

ventilated only if the hood is operating continuously. Chemical storage cabinets that need ventilation can be more effectively and economically ventilated with a separate, continuously-running exhaust system than by connecting them to a laboratory hood.



Protector® Acid Storage Cabinet with SpillStopper™ Work Surface

### Work Surfaces

The work surface, the slab or platform that supports the hood, should be made of a chemical-resistant and heat-resistant material compatible with the application. Some are designed with a dished surface to contain spills. Popular choices include molded epoxy resins, aluminum silicate, natural stone and other composite materials. Specialty hoods, such as those for perchloric acid and radioisotope applications, have built-in work surfaces. The smooth one-piece design of built-in work surfaces improves and simplifies decontamination procedures. Built-in work surfaces require a structural support underneath them.



SpillStopper™ Work Surface is dished to contain spills

### By-Pass Blocks

As described earlier, by-pass hoods are designed so that as the sash is closed, the constant volume of air entering the hood is redistributed to by-pass openings which helps reduce the potential for extremely high face velocities. By-pass blocks partially obstruct the by-pass openings above the sash of the hood to reduce the air volume demanded. When used with a sash stop, a by-pass block can conserve conditioned room air.

### Sash Stops

A sash stop is a device to restrict the sash opening height during normal working conditions. Maintaining the sash in a lowered position can reduce the exhaust volume demand so hoods with sash stops may utilize small blowers. This practice generally requires a by-pass block.

### Sash Position Alarms

To encourage users to keep the sash lowered, a sash position alarm provides audible and/or visual warning when the sash is raised above a designated level. Sash position alarms may be used alone or in conjunction with a sash stop.

### Fire Extinguishers



Hoods can be scenes of fires due to the nature of some applications. Some hood manufacturers offer automatic fire extinguishers that mount inside or adjacent to the hood and discharge at pre-determined temperature set points, providing around-the-clock protection.

*Snuffer™ Fire Extinguisher mounts inside the hood superstructure*

## Renovating Existing Laboratory Fume Hoods and Ductwork

While the changes may be subtle to the untrained eye, modern laboratory fume hoods are much more efficient at capturing fumes than many of the hoods built in the 60's and 70's. Hoods can now be tested according to ASHRAE 110-1995 and their performance levels compared to others. The addition of air foils at the front lip of the bench and other aerodynamic components have reduced turbulence and loss of containment from the hood.

It is usually not possible to retrofit older hoods to bring their performance up to today's standards. However, the addition of necessary components to an older hood is an expensive custom exercise that requires exacting engineering and design knowledge.

When replacing or adding to existing ductwork, extreme caution is required to avoid exposure to contaminants. In particular, ductwork exposed to perchloric acid can be potentially explosive and should only be removed by personnel experienced in handling these substances. Anytime an exhaust system is modified, testing should be done to ensure that the changes have not affected fume hood performance.

## Planning Laboratory Space

Whether adding one hood to an existing laboratory or installing hundreds in a new facility, planning is crucial. Because each hood affects the room's ventilation and traffic flow, the whole picture must be considered including the laboratory space, the building's ventilation and the hood's location in the room. The first and most imperative step taken should be to consult a qualified laboratory ventilation expert who can provide helpful advice through the planning, selection and installation phases.

### Laboratory Layout

In determining the amount of space necessary for the laboratory, a layout of all essential laboratory equipment should be made. The hood should always be located so that exit from the laboratory will not be impeded in the event of a fire or explosion within the hood structure itself. The hood should also be located away from high pedestrian traffic lanes in the laboratory to avoid disruptions to the airflow entering the hood. Cross currents from room ventilation should also be avoided, as they distort the flow of air essential to the safe operation of the fume hood. If ventilation components are in place, an attempt should be made to position the hood out of their influence (Figure 21). Some redirecting or blocking may be necessary. Hoods should not be installed in a location where it is likely to be affected by another piece of equipment, such as a biological safety cabinet or another fume hood. When possible, the hood side wall should be at least one foot away from the room wall to allow access to service connections.

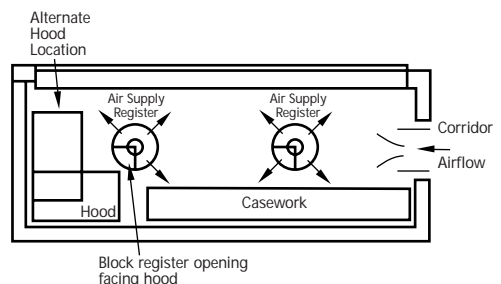

*Figure 21. Laboratory layout showing hood located away from exits and potential airflow disruptions*



### ***Sufficient Room Air***

A fume hood should not be installed without first considering whether the laboratory's supply air system will be able to replace all of the air exhausted. For proper hood operation and user safety, there must be sufficient room air available for exhausting to achieve the face velocity required. The National Fire Prevention Association (NFPA) Code 45 calls for replacing the laboratory with slightly less than the amount of air exhausted from the hood. This negative pressurization causes a slight inflow of air into the laboratory from corridors and non-laboratory spaces that helps to keep contaminants from spreading throughout the building.

In general laboratory situations, "Prudent Practices for Handling Hazardous Chemicals in Laboratories" states that the room air should be totally replaced at least 4-12 times an hour. Special laboratory functions may require an even greater number of air exchanges to ensure personnel safety. Open windows are not a substitute for a properly designed make-up air system.

"Air changes per hour" or "air changes per minute," however, are not a basis for ventilation criteria when environmental control of hazards, heat and/or odors is required. The required ventilation depends on the problem, not on the size of the room in which it occurs. The laboratory's safety officer should establish design criteria for room air changes.

### ***Energy Conservation***

For every 300 cubic feet per minute of air exhausted, approximately one ton of refrigeration is required. With energy resources becoming more scarce and more expensive every day, conservation is a high priority. Several methods to reduce the energy exhausted by a hood have been developed.

Variable air volume hoods use dampers or variable speed blowers to decrease the volume of air exhausted when demand is low, such as at night. Reduced air volume hoods function with by-pass blocks and sash stops which reduce the maximum sash opening areas thus lessening the air volume requirements. Auxiliary-air hoods can reduce the hood's demand for room air by replacing a portion of the conditioned air exhausted with supplemental air from outside the laboratory. Proper user training can enhance energy conservation as well.

### ***Noise Control***

The standard action level for noise in the work place sets permissible noise exposure at 85 dBA for eight hours. Following certain guidelines ensures that the noise in the laboratory created by a laboratory hood ventilation system never approaches the permissible noise level. The hood should be aerodynamically

designed with smooth edges, rounded corners and a belled entry at the duct collar to reduce the noise created by air passing through it. Properly sized duct components installed with the minimum number of angles reduces air movement noise. Installing the blower outside the laboratory, preferably on the roof, keeps the single largest source of noise away from the work place. Sturdily-constructed hoods and flexible duct connections minimize vibration noise.

## **Conclusion**

The purpose of the preceding discussion was to provide important factors to consider when selecting a laboratory hood ventilation system. Space limitations kept discussions brief. The General References that follow offer sources of in depth information on the factors presented in this booklet. Labconco can also provide technical assistance and help with laboratory planning. Our Ventilation Ventures Team (VVT) comprised of engineers and product specialists combine their expertise to help solve end users' laboratory ventilation problems. You can reach us at 800-821-5525 or 816-333-8811.

## **Laboratory Ventilation Standards**

### **Federal Register 29 CFR Part 1910**

*Non-mandatory recommendations from "Prudent Practices"*

- Fume hoods should have a continuous monitoring device
- Face velocities should be between 60-100 linear feet per minute (lfpm)
- Average 2.5 linear feet of hood space per person

### **Occupational Health and Safety**

**U.S. Department of Labor**

**200 Constitution Avenue N.W.**

**Washington, DC 20210**

**(202) 523-8151**

### **Industrial Ventilation-ACGIH**

- Fume hood face velocities between 60-100 lfpm
- Maximum of 125 lfpm for radioisotope hoods
- Duct velocities of 1000-2000 fpm for vapors, gasses and smoke
- Stack discharge height 1.3-2.0 x building height
- Well designed fume hood containment loss <0.10 ppm

### ***Industrial Ventilation, A Manual of Recommended Practice***

**22nd Edition, 1995**

**American Conference of Governmental**

**Industrial Hygienists**

**1330 Kemper Meadow Drive**

**Cincinnati, OH 45240-1634**

**(513) 742-2020**

### **ASHRAE 110-1995 Method of Testing Performance of Fume Hoods**

*Evaluates fume hood's containment characteristics*

- Three part test: Smoke generation, Face velocity profile, Tracer gas release @ 4 liters per minute
- Rated As Manufactured (AM) and As Installed (AI)

### **American Society of Heating, Refrigerating, and Air-Conditioning Engineers**

1791 Tullie Circle N.E.

Atlanta, GA 30329

(404) 636-8400

### **ANSI Z9.5-1992 Laboratory Standard**

*Covers entire laboratory ventilation system*

- Vertical stack discharge @ 2000-3000 fpm
- New and remodeled hoods shall have a monitoring device
- Ductless hoods should only be used with non-hazardous materials

### **American Industrial Hygiene Association**

2700 Prosperity Avenue, Suite 250

Fairfax, VA 22031

(703) 849-8888

### **SEFA 1-1992**

- Fume hood face velocities based on toxicity levels of chemicals
  - Class A—125 to 150 fpm
  - Class B—80 to 100 fpm
  - Class C—75 to 80 fpm

- Test method—face velocity profile and smoke generation

### **Scientific Equipment & Furniture Association**

1028 Duchess Drive

McLean, VA 22102

(703) 790-8661

FAX (703) 790-9573

### **NFPA 45 - 1996 Fire Protection for Laboratories Using Chemicals**

- Laboratory hoods should not be relied on for explosion protection
- Exhaust air from fume hoods should not be recirculated
- Services should be external to the hood
- Canopy hoods only for non-hazardous applications
- Materials of construction should have flame spread of 25 or less

### **NFPA 30 -1993 Flammable and Combustible Liquids Code**

- Approved cabinets may be metal or wood
- Vent location on cabinets are required
- Venting of cabinets not a requirement

### **National Fire Protection Association**

1 Batterymarch Park

P.O. Box 9101

Quincy, MA 02269-9101

(800) 344-3555

## **General References**

American Conference of Governmental Industrial Hygienists. *Industrial Ventilation, A Manual of Recommended Practice*, 22th Edition. Cincinnati, OH: 1995.

American Conference of Governmental Industrial Hygienists. *1991-1992 Threshold Limit Values for Chemical Substances and Physical Agents and Biological Exposure Indices*. Cincinnati, OH: 1991.

ASHRAE Standards Committee. *ASHRAE Standard*. Atlanta: ASHRAE Publications Sales Department, 1995.

British Standards Institution. *Laboratory Fume Cupboards*. Parts 1, 2 and 3. London: 1990.

Department of Labor, Occupational Safety and Health Administration. *29 CFR Part 1910, Occupational Exposures to Hazardous Chemicals in Laboratories; Final Rule*. Vol. 55, No. 21. Washington, D. C.: 1990.

DiBerardinis, L. et al. *Guides for Laboratory Design, Health and Safety Considerations*. Wiley & Sons, 1987.

McDermott, Henry. *Handbook of Ventilation for Contaminant Control, 2nd Edition*. Butterworth Publishers, 1985.

Miller, Brinton M. et al. *Laboratory Safety: Principles and Practices*. American Society for Microbiology, Washington, D.C.: 1986.

*Minimum Acceptable Face Velocities of Laboratory Fume Hoods and Guidelines for their Classification*. Oak Ridge National Laboratory #ORNL/TM 7400.

National Fire Protection Association. *NFPA 45 Fire Protection for Laboratories Using Chemicals*. Quincy, MA, 1996.

*NIH Guidelines for the Laboratory Use of Chemical Carcinogens*. NIH Publication No. 81-2385.

Rayburn, Stephen R. *The Foundations of Laboratory Safety, A Guide for the Biomedical Laboratory*. Springer-Verlag, New York: 1990.

Sax, N. Irving and Lewis, Jr., Richard J. *Rapid Guide to Hazardous Chemicals in the Workplace*. Van Nostrand Reinhold, 1987.

Schilt, Alfred A. *Perchloric Acid and Perchlorates*. The G. Frederick Smith Chemical Company, Columbus, OH: 1979.

Scientific Equipment & Furniture Association. *SEFA Laboratory Fume Hoods*. Standard 1991.

Steere, Norman. *CRC Handbook of Laboratory Safety, 2nd Edition*. CRC Press, 1971.

## Glossary

**access opening** That part of the fume hood through which work is performed; entrance or sash opening.

**activated charcoal filter** A filter containing activated carbon media designed to trap gaseous organic compounds by adsorption or absorption.

**air ejector** An air moving device which creates suction by venturi method to draw fumes through the ductwork to the atmosphere. An alternative to a blower.

**airflow monitor** A detection device mounted on a fume hood which alerts the operator to low airflow levels.

**air foil** Curved or angular member(s) at the fume hood entrance which helps to control the pattern of air moving into the hood.

**air volume** Quantity of air normally expressed in cubic feet per minute (CFM).

**auxiliary-air** Supply or supplemental air delivered to a fume hood to reduce room air consumption; make-up air or add-air.

**auxiliary-air hood** A fume hood designed with a means of providing supplemental air for the hood exhaust thereby reducing room air consumption.

**baffle** Panel located across the fume hood interior back which controls the pattern of air moving into and through the fume hood.

**biological safety cabinet** Safety enclosure with HEPA filter(s) which provides containment for airborne particulates such as infectious or carcinogenic agents; laminar flow biohazard hood. This enclosure is not a fume hood.

**blower** Air moving device, sometimes called a fan, consisting of a motor, impeller and housing.

**by-pass** Compensating opening that maintains a relatively constant volume exhaust through a fume hood, regardless of sash position, and that functions to limit the maximum face velocity as the sash is closed.

**by-pass block** Device which partially obstructs the by-pass opening above the sash of a by-pass hood, reducing the air volume demand.

**by-pass hood** A fume hood designed with openings above and below the sash to minimize fluctuations in face velocity as the sash is raised or lowered.

**California hood** A fume hood used to house distillation apparatus that can provide visibility from front and back or all sides, with horizontal sliding access doors along the length of the assembly. The hood, when connected to an exhaust system, contains and carries away fumes generated within the enclosure when doors are closed or when the access opening is limited.

**canopy hood** Suspended ventilating device used to exhaust heat, steam and odors. This device is not a fume hood.

**capture velocity** The air velocity at the hood face necessary to overcome opposing air currents, and to contain contaminated air within the fume hood.

**clean bench** An enclosure which directs HEPA-filtered air vertically or horizontally over the work area providing product protection. This enclosure is not a fume hood and does not provide personnel protection.

**conventional hood** A basic fume hood with an interior baffle and movable front sash.

**cross draft** A flow of air that blows into or across the face of the hood.

**damper** Device installed in a duct to control airflow volume.

**dead air space** Area inside a fume hood with no air movement.

**distillation hood** A fume hood that provides a work surface approximately 18 inches above the room floor, to accommodate tall apparatus.

**downdraft hood** An enclosure designed for applications involving heavier than air materials in which the blower is mounted below the work surface so that air is pulled down through a mesh surface before being exhausted to the outside. This enclosure is not a fume hood.

**duct** Round, square or rectangular tube or pipe used to enclose moving air.

**ductless carbon-filtered enclosure** An enclosure which houses filters to trap certain chemical fumes and vapors.

**ductwork** Duct and all the components necessary to connect pieces of duct together including adapters, reducers, elbows and couplings.

**effluent** Waste material (fumes, particles, smoke) discharged to the atmosphere.

**explosion-proof** Description for hoods or other devices with specially designed electrical components that totally contain and isolate electrical sparks from fume exposure so they cannot generate a fire or explosion.

**face** Front or access opening of a fume hood.

**face velocity** Speed of air moving into a fume hood entrance or access opening, usually expressed in feet per minute (fpm).

**fan** Air moving device, usually called a blower, consisting of a motor, impeller and housing.

**fume scrubber** An exhaust treatment device which uses water or chemical sprays to remove particles and to neutralize and dilute acids.

**glove box** A leak-tight chamber with glove ports and gloves for handling materials inside, a viewing window for observing, and a transfer chamber or door for loading and unloading. This enclosure is not a fume hood.

**HEPA filter** High-efficiency particulate air filter. A disposable extended-pleated dry-type filter with a minimum particle removal efficiency of 99.9% for thermally generated monodisperse DOP smoke particles with a diameter of 0.3 micron.

**laminar flow cabinet** Name applied to clean bench or biological safety enclosure that uses a smooth directional flow of air to capture and carry away airborne particles.

**liner** Interior lining used for side, back and top enclosure panels, exhaust plenum and baffle system of a fume hood.

**make-up air** Supply or supplemental air delivered to a fume hood to reduce room air consumption; auxiliary-air or add-air.

**manometer** Device used to measure air pressure differential, usually calibrated in inches of water.

**modified by-pass system** A method used by some variable air volume hoods whereby when the sash is lowered to a certain level, air volume is no longer reduced and some air volume enters through by-pass openings to maintain a volume great enough to adequately dilute and transport fumes.

**negative air pressure** Air pressure lower than ambient.

**positive air pressure** Air pressure higher than ambient.

**reverse airflow** Air movement from inside the hood toward the face of the hood.

**reduced air volume (RAV) hood** A fume hood which uses a sash stop and by-pass block to reduce the air volume demand so that a smaller blower can be utilized and energy savings realized.

**room air** That portion of the exhaust air taken from the room.

**sash** Movable transparent panel set in a fume hood entrance.

**sash stop** Device which restricts the height the sash can be raised.

**service fixture** Item of laboratory plumbing mounted on or fastened to laboratory furniture or fume hood intended to control the supply of piped gases and liquids for laboratory use.

**static pressure** Air pressure in a fume hood or duct, usually expressed in inches of water.

**static pressure loss** Measurement of resistance created when air moves through a duct or hood, usually expressed in inches of water.

**threshold limit value-time weighted average (TLV-TWA)** The time-weighted average concentration for a normal 8-hour workday or 40-hour work week, to which nearly all workers may be repeatedly exposed, day after day, without adverse affect as established by OSHA.

**transport velocity** Minimum speed of air required to support and carry particles in an air stream.

**variable air volume (VAV) hood** A fume hood which alters the exhaust volume based on demand, while maintaining a face velocity within a preset range.

**velocity pressure** Pressure caused by moving air in a fume hood or duct, usually expressed in inches of water.

**walk-in hood** A floor-mounted, full-height fume hood, designed to accommodate tall apparatus and to permit roll-in of instruments and equipment.

**weathercap** Device used at the top of an exhaust stack to prevent rain from entering the stack end.

**work surface** The slab or platform which supports the hood and rests atop a base cabinet or bench.



*Protecting your  
laboratory environment*

**LABCONCO**

**Labconco Corporation**

8811 Prospect Avenue

Kansas City, MO 64132-2696 U.S.A.

800-821-5525 / 816-333-8811

Fax: 816-363-0130

E-mail: [labconco@labconco.com](mailto:labconco@labconco.com)

Home Page: [www.labconco.com](http://www.labconco.com)